



**BIOMASS CHP / ANAEROBIC DIGESTION CHP  
DEPLOYMENT PROGRAMME  
CALL FOR PROPOSALS**

**Application Guidelines**

**Ver 1.6**



**CONTENTS**

1 Description of Call ..... 3

2 Definitions and Interpretation..... 3

3 Call Objectives..... 4

4 Eligible Organisations: Who Can Avail of the Call? ..... 5

5 Eligible Projects ..... 5

6 Eligible and Ineligible Costs..... 6

    6.1 Eligible Costs..... 6

    6.2 Ineligible Costs..... 7

7 What Level of Funding is Available? ..... 8

8 Required Information..... 8

9 Eligibility Requirements ..... 10

10 Evaluation Criteria ..... 11

11 Application, evaluation and approvals procedure ..... 12

12 Payment Procedure ..... 12

    12.1 First Payment:..... 12

    12.2 Second Payment: ..... 12

    12.3 Final Payment:..... 13

13 Installation Inspections and Operational Evaluation..... 13

14 SEI Power to Withdraw Grant..... 13

15 Terms and conditions..... 13

16 Useful Contacts..... 14

Appendix A - Technical Compliance ..... 16

Appendix B – Eligible Scheme Diagrams..... 17

Appendix C – Standard Calorific Values and Carbon Reference Values ..... 21

Appendix D – Primary Energy Savings ..... 22

Appendix E – Metering and Statistical Reporting ..... 24

## 1 Description of Call

The purpose of the Biomass CHP / Anaerobic Digestion CHP Deployment Programme Call for Proposals is to deliver increased market penetration of CHP schemes fuelled by biomass and biogas from anaerobic digestion, in fulfilment of government policy on bioenergy as detailed in the Bioenergy Action Plan for Ireland launched in March 2007.

The CHP programme, which includes fossil fired CHP, has an indicative allocation of €11M from the 2006 budget announcement of €65 million funding for renewable energy for the period 2006 – 2010. The Biomass CHP / Anaerobic Digestion CHP Deployment Programme is a subset of the CHP programme and has an indicative budget of €5-8 million (out of the €11M) over the period.

This Call for Proposals is open to Eligible Organisations (see section four) for projects that meet the detailed requirements set out in Eligible Projects (section five). Awards under this call will be on a discretionary basis and projects will be evaluated against evaluation criteria as outlined in section ten of this document. The call will remain open while there is funding available.

## 2 Definitions and Interpretation

For the purposes of this call the following definitions and interpretations will apply:

**“Anaerobic digestion (AD) biogas”** means gas arising from the process of anaerobic digestion in a controlled environment and excludes biogas from landfill sites.

**“Biomass”** means the biodegradable fraction of products, waste and residues from agriculture (including vegetal and animal substances), forestry and related industries, as well as the biodegradable fraction of industrial and municipal waste. It also includes purpose grown energy crops such as short rotation coppice willow and miscanthus. Priority will be given to projects utilizing an indigenous source of biomass.

**“Carbon Savings”** means reduction in the emission of carbon dioxide (CO<sub>2</sub>) resulting from displacing fossil fuels in the process of heat and power generation. It is quantified in tonnes of CO<sub>2</sub>.

**“Combined Heat and Power (CHP) plant”** means plant comprising eligible technology producing useful heat and power in a single process where the plant performance complies with the requirements stipulated in the EU Cogeneration “Directive 2004/8/EC”. For the purposes of this call the fuel must be either biomass, or biogas from anaerobic digestion.

**“Cogeneration”** means CHP

**“Connection offer”** means a grid connection offer issued by the transmission grid operator, or the distribution grid operator, of sufficient capacity to allow connection of the proposed CHP generation capacity.

**“Date of Operation”** means the date when the installed CHP plant commences full commercial operation.

**“Directive 2001/77/EC”** means Directive 2001/77/EC of the European Parliament and of the Council of 27 September 2001 on the promotion of electricity produced from renewable energy sources in the internal electricity market, as amended.

**“Directive 2004/8/EC”** means Directive 2004/8/EC of the European Parliament and of the Council of 11 February 2004 on the promotion of Cogeneration based on a useful heat demand in the internal energy market and amending Directive 92/42/EEC.

**“Eligible Organisation”** means any organisation as defined in section four of this Call for Proposals and that is eligible to apply for funding under this call.

**“Eligible Project”** means a project that meets the technical requirements described in section five of this Call for Proposals.

**“Eligible Project Boundary”** means the utilities area bounded by the Fuel Input Terminal Point and the Electrical and Heat off take Terminal Points - see Appendix B.

**“Eligible Technology”** means equipment that is installed with the primary purpose of energy production and that has been commercially proven on other projects with a minimum of 6000 commercial operation hours, either inside or outside the Republic of Ireland. In the case of Anaerobic Digestion CHP the cost of the digester itself can be included, except in sewage treatment works’ projects where the digester element is not an eligible cost. In the case of biomass, gasification processes and associated equipment are deemed not to be commercially proven technology and are therefore not eligible technology.

**“Full planning permission”** means, in the case of eligible domestic electricity a full grant (and not merely a decision to grant) of planning permission issued by the relevant planning authority (or, if it is the case, An Bord Pleanála) for the construction of the appropriate electricity generating plant at the site which has not expired where such permission is required under the Planning and Development Acts.

**“Licensed supplier”** means an entity licensed to supply electricity in the Republic of Ireland.

**“New CHP”** means new entire biomass-fired Combined Heat and Power package which could be either on a new site or retro-fitted to the heating and power networks at an existing site alongside existing boiler plant and grid connection.

**“Time Deadline”** means, as the context requires, any deadline set by or in accordance with these terms and conditions.

**“Useful Heat”** as defined in the EU Cogeneration Directive 2004/8/EC, means heat produced in a cogeneration process to satisfy an economically justifiable demand for heat or cooling which does not exceed the needs for heat or cooling and which would otherwise be satisfied at market conditions by energy generation processes other than cogeneration.

### **3 Call Objectives**

The objectives of this call are to:

- Increase the deployment of biomass CHP and anaerobic digestion CHP schemes in industrial, commercial, services and public sectors in the Republic of Ireland;
- Produce energy and carbon emission savings and fossil fuel displacement ;
- Increase electricity system security via more diversity of local embedded generating plant;
- Increase customer awareness and confidence in biomass CHP and anaerobic digestion CHP;
- Increase the capability of the Irish biomass CHP and anaerobic digestion CHP equipment supply chain.

In order to achieve these objectives the call will provide grant funding to projects that will deliver:

- Increased investment in new biomass CHP and anaerobic digestion CHP that have been designed appropriately to meet the specific circumstances of individual sites;
- New biomass CHP and anaerobic digestion CHP installations that operate in line with original design intent as evaluated after one year from the date of operation, as described in Section 13.
- New biomass CHP and anaerobic digestion CHP plants delivering primary energy savings in accordance with the EU Cogeneration Directive (2004/8/EC);
- New projects with a date of operation of 31 December 2010 at the latest.

## 4 Eligible Organisations: Who Can Avail of the Call?

The call is open to the following applicants that are defined as eligible organisations:

- Industrial, commercial and services organisations;
- Public sector organisations
- Energy Services Companies (ESCOs)

The applicant must be the legal entity that will hold beneficial ownership of the completed project and be registered in the Republic of Ireland.

Financial organisations that intend to lend money to a project, even if secured against income from the project, are not Eligible Organisations.

## 5 Eligible Projects

Projects utilising eligible technology in a combined heat and power scheme fuelled by biomass or biogas from anaerobic digestion are eligible for support under this call. However, for biomass projects, i.e. other than biogas from anaerobic digestion, the minimum eligible project scale is 100 kW<sub>e</sub> capacity and the programme will support only 5 biomass projects of less than 500 kW<sub>e</sub> capacity. For biogas from anaerobic digestion projects, the minimum eligible project scale is 50 kW<sub>e</sub>.

Projects involving the combustion of industrial or municipal wastes in what are commonly referred to as incinerators or waste to energy plants and to which the Waste Incineration Directive (WID) applies **are NOT eligible for support under this call**.

Eligible Projects must fulfil the following criteria:

- The plant must be installed in the Republic of Ireland.
- The plant must be new CHP, or conversion to CHP using new plant.
- The plant must be fuelled by (preferably indigenous) biomass, or biogas from an anaerobic digester.
- The plant must be designed to operate as a high efficiency CHP, in accordance with the EU CHP directive. Projects comprising individual heat only boilers and separate electrical generators that are not technically linked in a continuous process are not eligible. Refer to Appendix B for schematics of eligible and ineligible process arrangements.
- The plant must demonstrate primary energy savings (PES) as calculated by the methodology defined in the EU Cogeneration Directive 2004/8/EC, i.e. greater than zero for schemes with generating capacity less than 1MWe or greater than 10% for schemes with generating capacity above 1MWe (Simplified guidance is offered where it is applicable for the methodology for calculating Primary Energy Savings at Appendix D).
- The plant must demonstrate carbon savings as compared against the alternative fossil fuel fired power station and on-site boilers delivering the same energy outputs (useful heat and power)
- The project must be able to demonstrate it is deliverable within the timeframes of this call and be installed and achieve a date of operation on or before 31 December 2010.
- There is no upper limit on the electrical capacity of the prime mover. However projects with large prime movers in relation to heat load are unlikely to demonstrate primary energy savings in accordance with the EU CHP Directive 2004/8/EC.

## 6 Eligible and Ineligible Costs

### 6.1 Eligible Costs

Eligible costs are those costs for goods and services directly associated with the installation of the proposed CHP and items listed below for the eligible technology that falls within the Eligible Project Boundary (defined in Appendix B), limited to the maximum overall cost per kWe in Tables 1a to 1c.

All costs must be incurred on or after the date of a grant award; these can include:

- External detailed design and project management costs
- Equipment purchase and installation of CHP plant, including:
  - Prime mover and directly-associated ancillary equipment (i.e. heat connection to distribution network and electrical connection to main switch gear).
  - Fuel supply, processing and storage
  - Primary heat recovery equipment;
  - Heat and electricity monitoring equipment.
  - Electric switchgear
- Mechanical and electrical connections of plant items costs
- For anaerobic digestion, except in the case of sewage treatment works' projects, the digester cost can be included.
- Buildings & Civil Engineering work limited to the following:
  - Basic steelwork where it is part of the energy centre
  - Basic structure (e.g. barn) for fuel storage
  - Excavation for fuel storage (in the case of biomass)
  - Remedial works required to buildings altered during construction phase (e.g. demolition and restoration for access ways etc)

**Table 1a – Maximum Eligible Cost Limits for Biomass CHP**

<b>Plant scale ranges</b>	<b>Maximum cost/installed electricity generating capacity (Biomass)</b>
≥ 100 kWe and < 500 kWe	<b>€4,500/kWe</b>
≥ 500 kWe and < 1 MWe	<b>€4,000/kWe</b>
≥ 1 MWe and < 5 MWe	<b>€3,000/kWe</b>
≥ 5 MWe	<b>€2,000/kWe</b>

**Table 1b - Maximum Eligible Costs for Biogas CHP Plant including Digester**

Plant size ranges	Maximum cost/installed electricity generating capacity
≥ 50 kWe and < 100 kWe	€4,500/kWe
≥ 100 kWe and < 500 kWe	€4,000/kWe
≥ 500 kWe and < 1 MWe	€3,500/kWe
≥ 1 MWe	€3,000/kWe

**Table 1c. Maximum Eligible Costs for Biogas CHP Plant excluding Digester** (i.e. CHP at sewage treatment works)

Plant scale ranges	Maximum cost/installed electricity generating capacity
≥ 50 kWe and < 100 kWe	€2,000/kWe
≥ 100 kWe and < 500 kWe	€1,800/kWe
≥ 500 kWe and < 1 MWe	€1,000/kWe
≥ 1 MWe	€1,000/kWe

## 6.2 Ineligible Costs

**Ineligible costs include all costs relating to the following:**

- back-up, top-up and any other heat-only boilers; even if within the Eligible Project Boundary
- civil engineering works for access roads etc, for biomass delivery
- on site weighbridges and fuel sampling (moisture content) for biomass schemes
- power only prime movers for standby
- secondary heat recovery equipment and heat delivery system (heat distribution pipe network)
- internal staff costs,
- Development costs including feasibility study costs.
- All costs associated with the operation of the equipment following commissioning or acceptance by the end user as appropriate.
- All costs associated with progressing applications for planning or other consents.
- Purchase cost of any land on which the project is built.
- Input VAT

- Interest charges, bad debts, advertising, entertaining.
- Hire purchase interest and any associated service charges.
- Mark up and profits.
- Profit earned by a subsidiary or by an associate undertaking work sub-contracted under the project.
- Notional costs (e.g. opportunity costs).
- Audit fee for certification of claims by an independent accountant.
- Grants that contribute directly to a company's distributed profits.
- Funds to build up a reserve or surplus.
- Retrospective funding.
- Loan repayments.

## 7 What Level of Funding is Available?

Grant support of up to **30%** of the eligible capital costs may be awarded to Biomass CHP and Anaerobic Digestion CHP projects, with an indicative maximum grant that can be allocated to a project of €1,500,000.

*SEI reserves the right to update and revise the levels of grant funding available to the various project types and technologies offered under this Call.*

## 8 Required Information

In order for the technical and economic viability of the project to be evaluated, and for an informed judgement to be made on the ability of the project team, to deliver the proposal within the required time scales, the following information, as requested mostly in table A2.1 of the application form, will be required:

- Site map and Ordnance Survey grid reference showing location of the proposed CHP plant and identified heat loads.
- A feasibility study must be produced and be less than 3 years old; the study must cover at least the issues listed in Appendix A relevant to the proposed plant. The outcomes of this study must be provided in the application form and all applications must be accompanied by a copy of the feasibility study.
- Detailed business plan including evidence of balance of funding in the form of a Letter of Intent or similar document.
- Technology type and size of Prime Mover (i.e. steam turbine, engine etc.), rated electrical output kWe, thermal output kWt.
- For biomass schemes, details of how much heat from the CHP is to be used to dry the biomass prior to combustion
- For anaerobic digestion CHP details of how much heat from the CHP is to be used for heating the digester
- Details of fossil fuels and other non-biomass fuels used for backup and top up.
- Design data on fuel input, heat and electrical output and operational performance including expected annual full load operational hours. Plant performance must be

calculated based on the Net Calorific Value (NCV) of the fuel either verified by fuel trials, or otherwise taken from the Standard CV values given in Appendix C.

- Details of how CHP fuel inputs and electrical and useful heat outputs will be monitored.
- Potential Primary Energy Savings calculated in accordance with Directive 2004/8/EC.
- Potential carbon savings using reference case details. Applicants must use the 'carbon dioxide factors for carbon savings' reference values in Appendix D to calculate potential carbon savings.
- Details of annual CHP heat uses including heat prices and contracts/agreement in principle if available, including details of whether the load exists, or is new but in an advanced stage of development, or is conceptual/in early stages of development.
- Details of annual CHP power uses including power prices and contracts/agreement in principle if available, including details of whether the load exists, or is new but in an advanced stage of development, or is conceptual/in early stages of development.
- Details of fuel supply chain including supplier contact details, fuel costs and contracts/agreement in principle.
- Details of electrical grid Connection Offer, or modification to existing grid connection agreement, including copy of agreement or a report on progress towards obtaining such agreement.
- Details of generating licence, or authorisation to construct a generating station, where applicable.
- Copy of planning consent or a report on progress towards obtaining such consent, where applicable.
- Evidence of Principal Client's capability in relevant field.
- Copy of consultant capability statement and evidence of the capability of partners
- Proposed project development programme including key milestone dates (including planning and grid connection, where applicable) as requested in section A1.2 of the Application Form
- Declaration of other grant applications/offers for the same plant items as requested in section A3 of the Application Form.
- Evidence of a current tax clearance certificate.

Applications that are not accompanied by this list of information will be considered incomplete and will be deferred.

## 9 Eligibility Requirements

The eligibility requirements in this section must be addressed in the application.

<b>Required Information as per Guidelines Section 8</b>	All Information requested in list above provided or clearly proven to be not applicable.
<b>Balance of funding</b>	Finance mechanism fully in place or Letter of Intent available. It is acceptable to have provisional finance offers that are dependent upon securing a Grant under this scheme.
<b>Proportion of biomass burned by CHP</b>	Biomass is greater than or equal to 90% of energy input to CHP on a Net Calorific Basis (NCV)
<b>Plant Performance and Primary Energy Savings</b>	Plant design results in operation as a high efficiency CHP and delivers minimum required Primary Energy Savings as calculated according to Directive 2004/8/EC
<b>Project schedule</b>	Detailed project schedule identifying key milestones – must include planning and grid connection, where applicable.  (Note: - Applicants should assume 12 week period from grant application to SEI approval in laying out the project schedule)

### Additional Eligibility Criteria

In addition to the specific organisation and project eligibility, the following is a list of general requirements:-

- Applicants must agree to have the projected annual energy savings verified and certified by an SEI appointed inspector, stating that the CHP plant will comply with the requirements of the EU CHP Directive (2004/8/EU);
- Applicants must agree to install heat and electricity monitoring necessary to determine electricity from the CHP plant as per Annex II, and the primary energy savings as per Annex II of the EU CHP Directive (2004/8/EC); and the Guidelines for the implementation of the Annexes II and III of the Directive (Simplified guidance is offered where it is applicable for the requirements for metering and provision of statistics at Appendix E);
- Applicants must agree to provide annual fuel usage and electricity and useful heat output in response to a survey by SEI representatives for the purposes of reporting to the European Commission and publication of the statistics as required under the EU CHP Directive (2004/8/EC).

Application forms must be completed in full except where the Guidelines clearly state the section is optional.

Statements such as ‘Information to follow’ or ‘to be confirmed’ etc. are not acceptable and will be deemed as non-completion.

## 10 Evaluation Criteria

The goal of this programme is to deliver installed capacity of biomass CHP and anaerobic digestion CHP representing value for money, and in compliance with EU directive requirements. Projects will be evaluated with particular reference to the evidence supporting value for money, feasibility of the proposed scheme, capability of the participants to deliver and a schedule of activity that is realistic and achievable within the time constraints of the programme.

The following table identifies the evaluation criteria that will be central to the application review process.

<b>Value for money</b>	Carbon saving cost effectiveness	Cost effectiveness of the CO <sub>2</sub> equivalent emissions reduction / avoidance.
	Replication potential	Potential for replication of the project in Ireland
<b>Project feasibility</b>	Heat load	Is the heat load existing and under contract, or under development or at the conceptual stage.
	Electricity load	Is the electricity load existing and under contract, or under development or at the conceptual stage.
	Fuel Supply	Is the fuel supply identified with contract in principle, identified with no contract or not yet identified. Is the fuel supply source nearby.
<b>Capability of participants</b>	Applicant proven capability in relevant field	What is the relevant capability and experience of the applicant
	Consultant proven capability in relevant field	What is the relevant capability and experience of the consultant
<b>Achievable schedule</b>	Ability to deliver within time scales	Is the project schedule realistic, clearly defined with allowances for project overruns and within the programme timeframes.
	Grid Connection	Is grid connection agreement, or modification to existing grid connection agreement, in place, or electricity company contacted and grid connection point analysis being conducted prior to agreement.
	Generating licence	If applicable, is a generating licence, or authorisation to construct a generating station granted, or applied for and awaiting decision.
	Planning consent	If required, is full planning consent granted, or applied for and awaiting decision.

**SEI reserves the right to interview at our discretion during the evaluation process.**

## 11 Application, evaluation and approvals procedure

Application forms are available online at [www.sei.ie/bio\\_chpgrants](http://www.sei.ie/bio_chpgrants). It is important that the applicants complete the correct application form for their project.

Along with the completed application form, applicants must submit a valid Tax Clearance Certificate (a scanned or faxed copy of the valid tax clearance certificate is acceptable for electronic applications).

Applicants should send an electronic version of the application form containing electronic signatures to [bio\\_chpgrants@sei.ie](mailto:bio_chpgrants@sei.ie).

Alternatively, applicants that do not have electronic signatures should send:

- (i). an electronic version of the completed application form to [bio\\_chpgrants@sei.ie](mailto:bio_chpgrants@sei.ie), and
- (ii). a hard copy containing the original signatures to:

**Bio\_CHP Deployment Programme**  
**Sustainable Energy Ireland**  
**Wilton Park House**  
**Wilton Place**  
**Dublin 2**

The indicative decision time from the receipt of a complete application form is twelve weeks. If approved, a grant agreement will be issued to the applicant. The offer will only be validated upon the applicant indicating acceptance of the offer by returning a signed copy of the grant agreement to SEI, which must be received within 30 days of date of issue.

## 12 Payment Procedure

On submission of appropriate documentation, SEI will transfer grant funds electronically to the applicant's bank account and issue an accompanying letter notifying payment to the applicant.

### 12.1 First Payment:

The first payment of up to 30% of the grant award will be made upon demonstrated progress as agreed between SEI and the applicant..

### 12.2 Second Payment:

The second payment of up to 50% of the grant award (payment cannot exceed 30% of incurred costs at the time of second payment) will be made, providing the following conditions have been met:

- a. CHP unit has been commissioned;
- b. Submission of a completed **Bio\_CHP Project Commissioning Report** (shortly available from SEI web-site), by an installer/supplier to certify that the plant installation complies with the energy savings and metering eligibility requirements.
- c. Payment request form, invoices, receipts and a current Tax Clearance Certificate

### **12.3 Final Payment:**

The final payment of the balance of the grant award will be made one year after the date of operation, on submission of a completed Bio\_CHP Project Operation Report (shortly available from the SEI web-site) by an SEI appointed inspector. This report is to certify that the plant operates in line with the design intent to within a tolerance of +/- 5% of expected output, and that it delivers primary energy savings as calculated in accordance with the EU CHP Directive 2004/EC/8 method.

For all payments the applicant must provide proof, in the form of invoices of the eligible costs incurred that the grant payment is equal to or less than the grant offer percentage. Where insufficient eligible costs are incurred to justify the full value of the grant payment, the payment will be reduced on a pro rata basis.

Operation is to be evaluated based upon 1 years continuous operational data and not on instantaneous data at the time of the visit.

Where the conclusion of the operation report is that the plant does not meet the requirements, the applicant will forgo the final grant payment.

## **13 Installation Inspections and Operational Evaluation**

All completed CHP installations will be the subject of site inspections at the discretion of SEI, to verify the installation has been implemented in accordance with the scope of work defined in the application.

All CHP installations will be subject to performance inspection, by an SEI appointed inspector, after one year from the date of operation.

The inspector will be required to complete a **Bio\_CHP Project Operation Report** to certify that the plant currently operates in accordance with design intent and complies with the energy efficiency requirements of EU CHP Directive (2004/8/EC). This report will also include a customer satisfaction element and will be used by SEI to inform ongoing development of quality assurance within the programme.

Where the findings of the Bio\_CHP Project Operation Report disclose that either primary energy savings (as defined in EU CHP Directive 2004/8/EC) are not achieved or operation is not within +/- 5% of design intent of input and output energy flows, the applicant will not be paid the final grant instalment.

Where a project does not achieve a date of operation of 31 December 2010 at the latest, SEI reserves the right to recall any grant funding paid prior to that date.

## **14 SEI Power to Withdraw Grant**

Applicants will be required to adhere strictly to the scope and timescales within their application. Where delivered plant deviates from and/or key milestone dates identified on the application form are not met SEI reserves the right to withdraw grant funding and to reallocate, without prejudice, to alternative projects.

## **15 Terms and conditions**

1. Application Form and Terms and Conditions are those published on the SEI website on the date of submitting the application.

2. The applicant must ensure that he/she submits the latest version of the relevant application form (see [www.sei.ie/bio\\_chpgrants](http://www.sei.ie/bio_chpgrants) for the latest version);
3. The applicant must be the intended owner of the CHP Plant, located in the Republic of Ireland, in respect of which the grant application is made;
4. The applicant must install a new product;
5. Approval of grant only becomes valid upon receipt by SEI from the applicant of the issued Grant Agreement signed by the applicant to indicate his/her acceptance;
6. Grant approval must be in place before any purchases are confirmed or installation works commenced. No payments will be made retrospectively for costs incurred prior to approval being granted;
7. The grant, once approved, is only payable in respect of the Plant identified in the Application Form and referenced in the Grant Agreement;
8. Should the applicant's plant be selected for inspection, the applicant must provide access to SEI or its authorised agents;
9. The applicant must obtain all necessary consents and statutory approvals and have authority to install the CHP system;
10. The applicant must be prepared to participate in follow-up research (telephone or postal questionnaire) as may be commissioned by SEI to establish the Programme's impacts and achievements. This will also include the acquisition of information and data for the development of case studies for wider dissemination (protecting as appropriate all confidential or commercially sensitive information / data);
11. SEI undertakes to use its best endeavours to hold confidential, any information provided by applicant subject to its obligations under law, including the Freedom of Information Act 1997 (as amended). Should applicants wish that any of the information supplied by them should not be disclosed because of its sensitivity, they should, when providing the information, identify the same and specify the reasons for its sensitivity. SEI will consult with applicants about such information before making a decision on any Freedom of Information request received.
12. Data Protection – Any personal information which you volunteer to SEI will be treated with the highest standards of security and confidentiality, strictly in accordance with the Data Protection Acts, 1988 & 2003. SEI, as data controller, and its agents, will store the information you provide on its database and fully respect the confidentiality of the data provided. The information you provide will be used for evaluation purposes and to facilitate the administration of the grant process. This may require that your data be supplied to and discussed with, in confidence, any person or organisation helping to assess and monitor this application. These persons will be subject to the same requirements for protection of confidentiality. Your signature on this Application Form is treated as confirmation that SEI and its agents may use the information you have supplied for the aforementioned purposes.
13. Project timescales – The project programme provided by the applicant on the Application form, including key milestone dates, will form part of the Conditions of Contract if a grant offer is awarded. In the event that any of these deadlines are not met SEI reserves the right to review the offer of grant and withdraw it.

## 16 Useful Contacts

### **Programme Administrator**

Grants Administrator  
Sustainable Energy Ireland  
Wilton Park House  
Wilton Place  
Dublin 2

**Phone** 01 808 2138/2035

**Fax** 01 808 2013

**Email** [bio\\_chpgrants@sei.ie](mailto:bio_chpgrants@sei.ie)

### **Technical Advice / Support**

Bio\_CHP Programme Manager  
Sustainable Energy Ireland  
Wilton Park House  
Wilton Place  
Dublin 2

**Phone** 01 808 2012

**Fax** 01 808 2013

**Email** [bio\\_chpgrants@sei.ie](mailto:bio_chpgrants@sei.ie)



This document together with the necessary forms may be downloaded from SEI's website [www.sei.ie/bio\\_chpgrants](http://www.sei.ie/bio_chpgrants)

**IMPORTANT NOTICES**

SEI accepts no liability in respect of any dispute, claim or cause of action arising out of, or in relation to, any product, equipment, work, system, installation or commissioning in respect of which grant approval was given by SEI. No undertaking, guarantee, assurance or other warranty, express or implied, is given by SEI, or any of its agents or servants, in respect of the cost, quality, efficiency and/or benefit of any work, equipment, product, service or installation provided under the Scheme.

The information provided herein and on SEI's website is provided solely for the purpose of providing assistance to the public, and is not intended to warrant or guarantee the quality of the product and/or the installation chosen by the grant applicant.

## **Appendix A - Technical Compliance**

### **Requirements for Contents of Feasibility Study**

**1. Clearly stated objectives?**

**2. Adequate information for a judgment to be made on the merits of proceeding with the proposed project including:**

- the heat and electricity requirements of the site;
- the technical specification and proposed operating pattern of the CHP plant in sufficient detail to support plant specification and ordering;
- requirements for the plant to be connected to the electricity and fuel supply systems;
- the reference case/plant against which the proposed CHP plant performance is to be compared;
- provision for any likely import or export of electricity or heat including back-up;
- the economics of the plant;
- primary energy savings resulting from the plant;
- carbon emission savings resulting from the plant;
- fuel supplies to the plant and robustness of supplies;
- a plausible schedule for construction and commissioning of the plant;
- any necessary building construction or alternation;
- Requirements to meet regulation and licensing provisions?

**3. Consideration of the metering and annual energy savings to meet the requirements of the EU CHP Directive (2004/8/EC)**

## Appendix B – Eligible Scheme Diagrams

### Additional Technical Definitions – Eligible Project Boundary and Eligible Project Definitions

**Eligible scheme - Heat is delivered simultaneously as a by-product of power generation**

**Note – A Gas Turbine (GT) is required in small biomass schemes such as where biomass is burned to drive hot air through a turbine.**

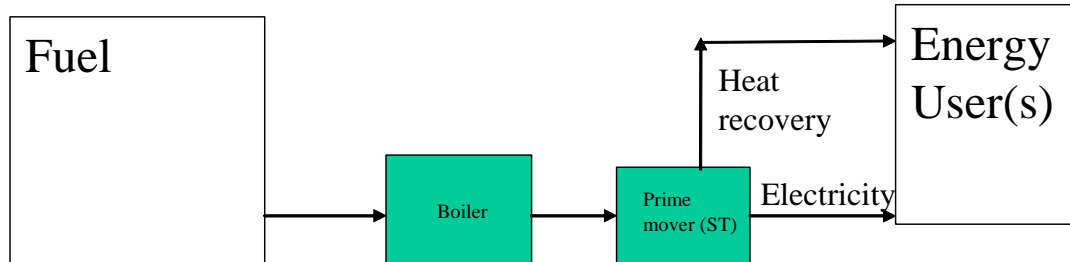
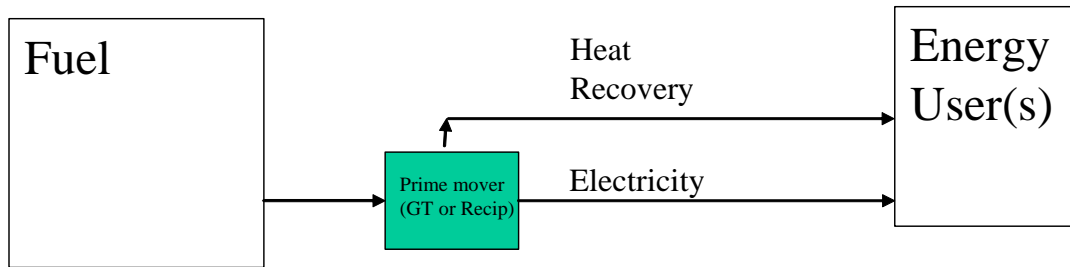

**Ineligible Scheme - Heat and power generation are independent**

This arrangement is not CHP and will not be eligible for a grant

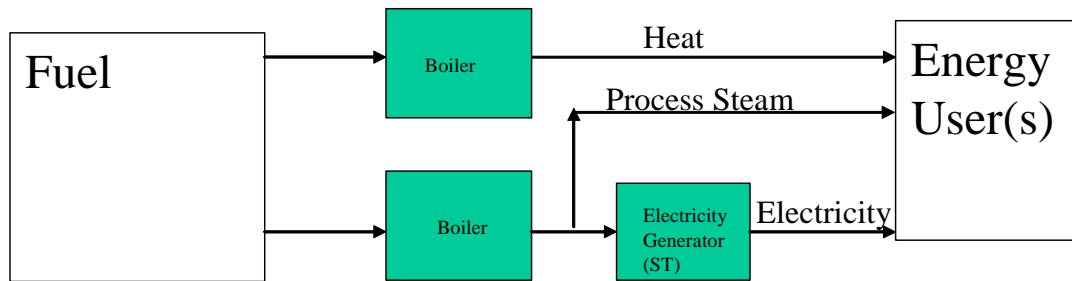
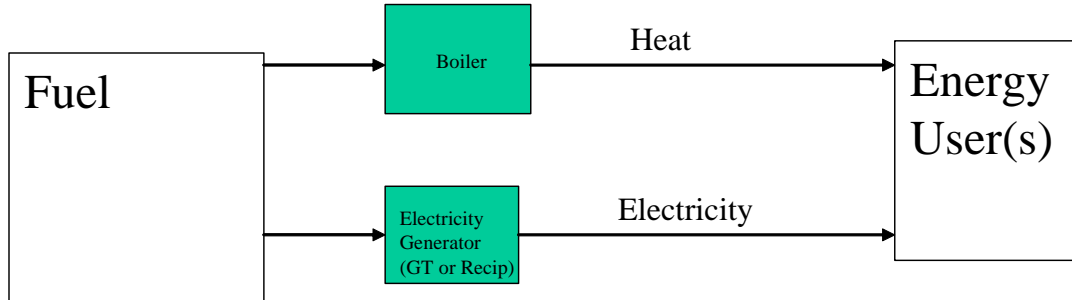

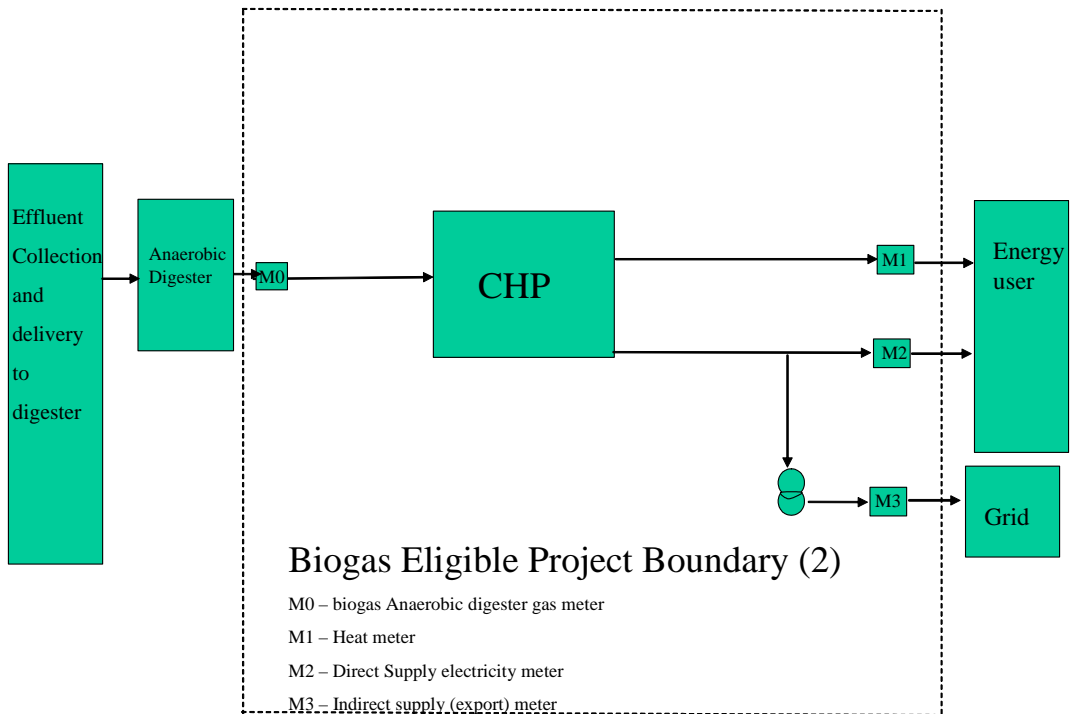
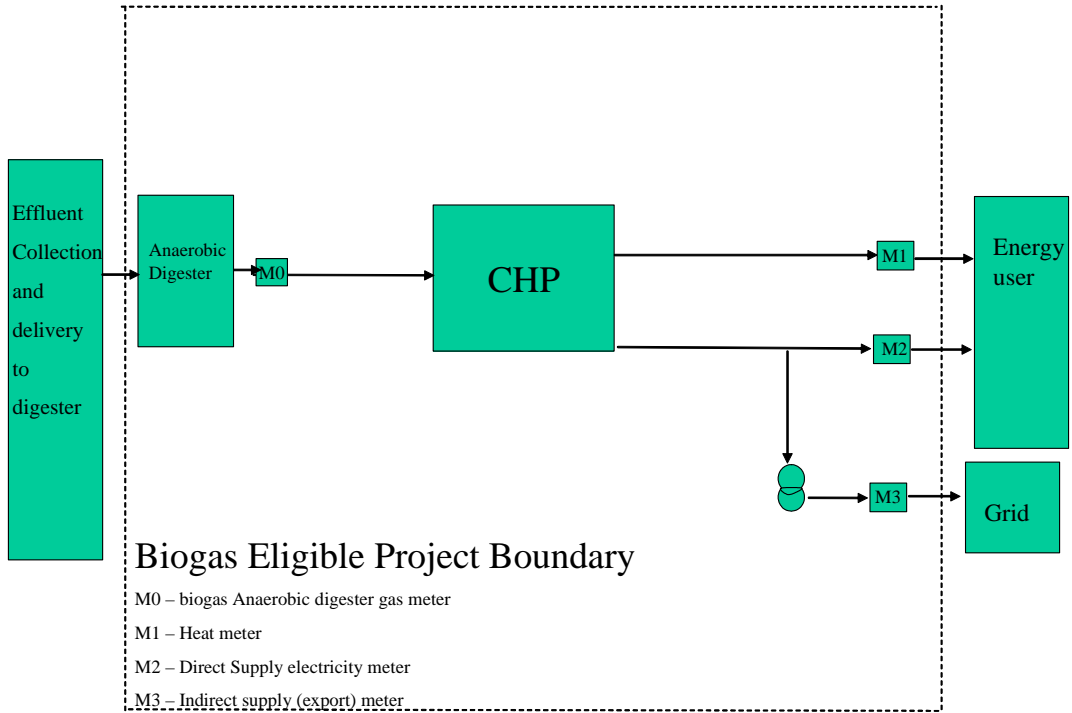

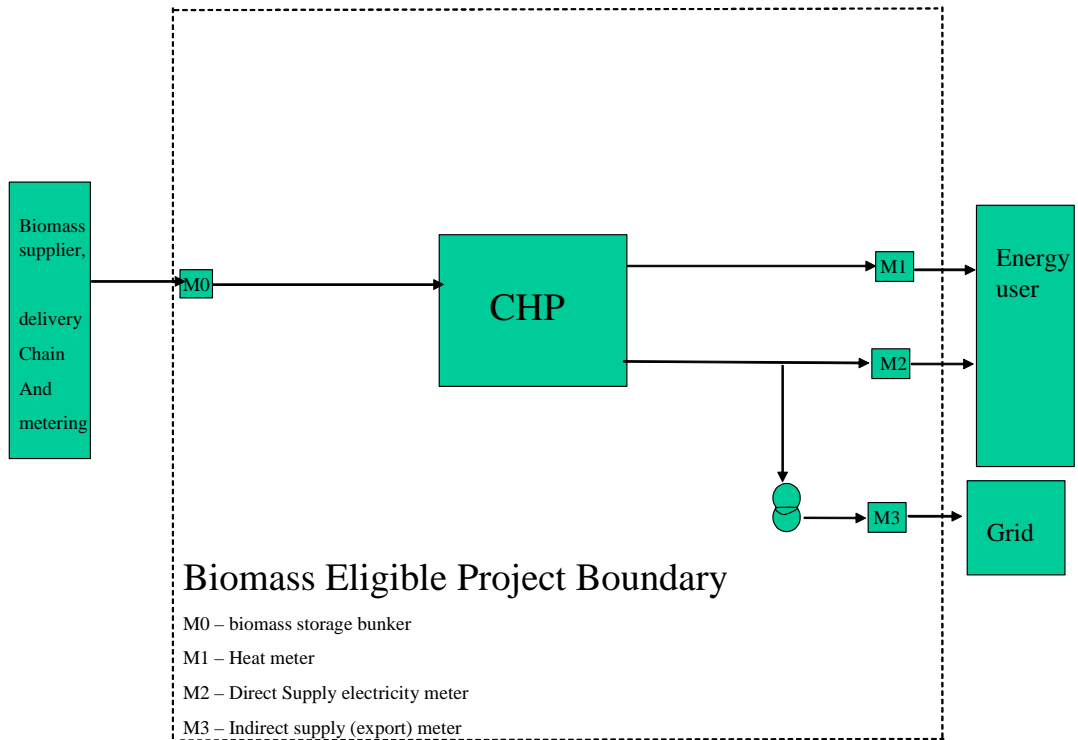

## Appendix C – Standard Calorific Values and Carbon Reference Values

### Standard Calorific Values

#### Biomass (Varies with moisture content-typically:-)

Wood	18.0 GJ/Tonne (Net CV) @ 0% moisture content
Straw	13.5 GJ/Tonne (Net CV) @ 20% moisture content
Short Rotation Coppice	9.0 GJ/Tonne (Net CV) @ 50% moisture content

#### Biogas Typically:-

Sewage Gas 21MJ/m<sup>3</sup>

Other AD Gas 21MJ/m<sup>3</sup>

### Carbon dioxide factors for carbon savings

- Displaced Centrally Generated Electricity: 0.637 tonnes CO<sub>2</sub>/MWh<sub>e</sub> - {Based on Energy in Ireland 1990 - 2005 - Trends, issues, forecasts and indicators}

#### - Displaced fossil fuel in boilers

Fuel oil 0.274 tonnes CO<sub>2</sub>/MWh<sub>fuel (LHV)</sub> or other for other fuels {Based on Energy in Ireland 1990 - 2005 - Trends, issues, forecasts and indicators}

#### - Alternative fossil fuels -

Natural gas : 0.205 tonnes CO<sub>2</sub>/MWh<sub>fuel (LHV)</sub>

Coal : 0.341 tonnes CO<sub>2</sub>/MWh<sub>fuel (LHV)</sub>

## Appendix D – Primary Energy Savings

### Simplified Guidance for the Calculation of Primary Energy Savings to meet the Requirements of EU Directive (2004/8/EC)

1. This appendix provides simplified guidance which it is believed apply to meeting the EU Directive requirements on primary energy savings for the majority of small-scale CHP plants likely to be eligible under the CHP Deployment programme. It is offered to assist applicants. However for the full requirements of the Directive reference must be made to the EU Directive *[Insert Re]* itself and the EU Guidelines for the Implementation of the Directive *[Insert ref]*.

2. To be eligible for grant support small-scale CHP plants are required to be “high-efficiency co-generation” based on useful heat produced in a co-generation process to satisfy an economically justifiable demand for heating or cooling demand, and achieve primary energy savings greater than zero calculated by the method and using the reference values in the Directive and Guidelines for Ireland as illustrated in paragraph 4. No heat supplied from heat-only boilers nor heat dumped or rejected to non useful demands can be included in the calculation of useful heat.

3. For most plants eligible in the CHP Deployment Programme if the overall yearly efficiency of the CHP plant, based on lower or net calorific value, is greater than 75% then all of the electricity produced can be counted as co-generation and used in the calculation of primary energy savings and for reporting purposes as described in Annex II of the Directive. If the overall efficiency is less than 75% then the electricity generated must be calculate by the methodology outlined in Annex II of the Directive and this value substituted in the calculations outline in paragraph 4.

#### 4. Calculation of primary energy savings

The calculation of Primary Energy Savings (PES) is based on the annual useful heat output of the CHP plant and the annual electrical output of the CHP plant as described in Annex III to the Directive.

The calculation uses the following formula:

$$PES = \left( 1 - \frac{1}{\frac{CHP H\eta}{Ref H\eta} + \frac{CHP E\eta}{Ref E\eta}} \right) \times 100\%$$

Where:

- PES is the primary energy savings delivered by the CHP plant. This must be greater than zero for plants less than 1MWe capacity eligible under the CHP Deployment Programme.
- CHP H $\eta$  is the efficiency of the CHP plant’s heat production defined as annual useful heat output divided by the annual fuel input.
- Ref H $\eta$  is the efficiency reference value for separate heat production (see below).
- CHP E $\eta$  is the efficiency of the CHP plant’s electricity production defined as annual electricity from CHP divided by the annual fuel input.
- Ref E $\eta$  is the efficiency reference value for separate electricity production (see below).

The electricity and heat references are dependent on the fuel used in the CHP plant. For electricity there is also an adjustment depending on the voltage level of the connection, except for the cases of wood fuels and biogas. The reference figures are:

**Electricity**

Fuel	Connection < 400 V		Connection ≥400 V and ≤50 kV	
	Used on site	Exported	Used on site	Exported
Natural gas	45.6%	49.0%	49.0%	50.1%
Gas oil or LPG	38.4%	41.3%	41.3%	42.2%
Wood fuels	33.0%	33.0%	33.0%	33.0%
Agricultural biomass (solid)	21.5%	23.125%	23.125%	23.625%
Biodegradable (municipal) waste	21.5%	23.125%	23.125%	23.625%
Biofuels (liquid)	38.012%	40.885%	40.885%	41.769%
Biogas	42.0%	42.0%	42.0%	42.0%

**Heat (Hot Water or Steam):**

Fuel	Steam or Hot Water	Direct use of exhaust gases: temperature ≥ 250 °C
Natural gas	90%	82%
Gas oil or LPG	89%	81%
Wood fuels	86%	78%
Agricultural biomass (solid)	80%	72%
Biodegradable (municipal) waste	80%	72%
Biofuels (liquid)	89%	81%
Biogas	70%	62%

**Notes:**

- If more than one fuel is used then you need to use the references in proportion to the shares of the fuels used. For example if the plant uses 90% natural gas and 10% gas oil then the reference for heat is  $(90\% \times 90.0\%) + (10\% \times 89.0\%) = 89.9\%$ .
- If some power is used on site and some is exported then the references are used in proportion to the share of export versus the share of own use. For example if 30% of electricity generated is exported and 70% is used on site for a CHP plant using natural gas and connected at 10 kV, the reference for electricity is  $(30\% \times 50.1\%) + (70\% \times 49.0\%) = 49.3\%$ .
- If the overall CHP installation efficiency is less than 75% and a calculation of the  $E_{CHP}$  and  $F_{CHP}$  has been necessary, then fuel split and references for grid exported and on used are applied in the same proportion as the whole scheme, before correction.

## **Appendix E – Metering and Statistical Reporting**

### **Simplified Guidance for the Metering and Statistical Reporting to meet the Requirements of EU Directive (2004/8/EC)**

1. This appendix provides simplified guidance which it is believed apply to meeting the EU Directive requirements on metering and statistical reporting for the majority of small-scale CHP plants likely to be eligible under the CHP Deployment programme. It is offered to assist applicants. However for the full requirements of the Directive reference must be made to the EU Directive itself and the EU Guidelines for the Implementation of the Directive.

#### **Metering**

2. Suitable metering is required to allow:

- measurement of electricity output from high-efficiency co-generation;
- fuel input, electricity output, and useful heat output to permit calculation of primary energy savings electricity;
- statistical reporting to the European Commission.

3. Metering requirements differ for the two types of plant that will mainly be eligible under the CHP Deployment Programme:

- CHP plants with fixed heat to power ratios and no heat rejection facilities: ( see Diagram 1);
- All other CHP plants (see Diagram 2).

#### Plants with fixed heat to power ratios and no heat rejection facilities

4. This section applies where:

- The CHP installation has a fixed power to heat ratio and, therefore, operates in direct proportion to the needs for heat (normally hot water and space heating) and when there is insufficient or no heat demand shuts down.
- The CHP installation must not have any possibility to reject heat, using either a cooling tower, heat dump radiator or other similar device.
- The CHP installation uses only one type of fuel.
- There is only one prime mover used in the CHP installation (the prime mover is the engine of the CHP Plant).

If the CHP installation meets all these criteria then the only metering that must be installed is for electrical power output. The heat output and fuel input can be calculated using the manufacturer's data sheets.

Diagram 1 shows the location of the metering (note in this case only meter M3 is needed). Diagram 1 shows also the metering of the fuel input (M2). Although this is not required, it is nevertheless good practice to meter the fuel input.

DIAGRAM 1: Example of metering on a small-scale CHP Plant – Fixed heat to power ratio

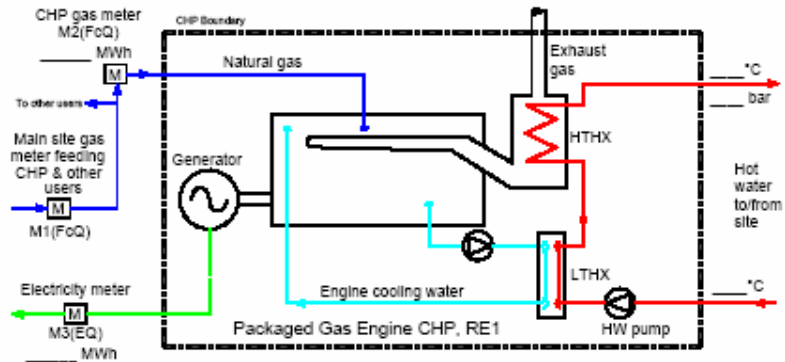

The electricity metering shall be a commercial/industrial 3-phase electricity meter, dedicated to the CHP installation, clearly labelled and of a quality that is suitable for billing. In cases where all the electricity is used on site and therefore no export to the public grid takes place a meter on the CHP installation output is sufficient. If power is exported to the public grid then this must be metered separately as well as the total CHP Power Output.

All Other CHP Installations

All CHP installations that do not meet the criteria in the previous section must meter the fuel input, electrical power output and useful heat output. If more than one CHP prime mover is installed the metering must be sufficient to identify the total CHP performance, this may require separate metering. If more than one fuel is used by the CHP installation then each fuel must be metered separately. If more than one useful heat output is produced then each one needs separate metering, unless they are combined before delivery to site. Note that heat metering must be after any heat rejection facilities.

DIAGRAM 2: Example of metering on a small-scale CHP Plant

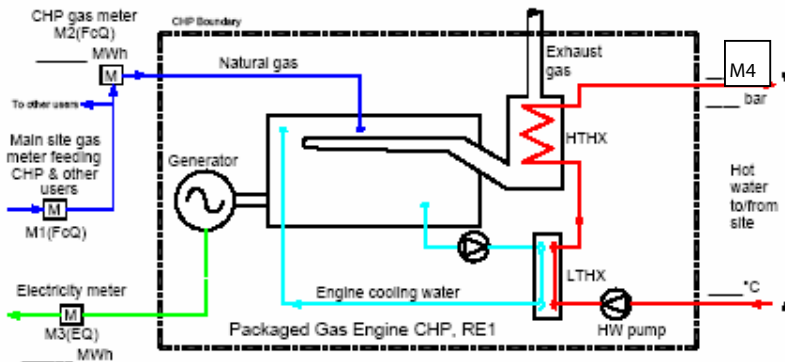

The electricity metering shall be a commercial/industrial 3-phase electricity meter, dedicated to the CHP installation, clearly labelled and of a quality that is suitable for billing. In cases where all the electricity is used on site and therefore no export to the public grid takes place a meter on the CHP installation output is sufficient. If power is exported to the public grid then this must be metered separately as well as the total CHP Power Output.

In the case where the CHP Plant is the sole user of the fuel, fuel billed from the fuel supplier is sufficient. In all other cases metering of the fuel is necessary.

Metering Compliance

In most cases the equipment supplier or consulting engineer should be able to ensure compliance with these requirements

For all metering the following requirements must be met:

- Validation procedures for the monitoring system should be in place either by direct calibration or by validating each of the components within the measurement system;
- Periodic calibration should be carried out by the manufacturer or a suitable accredited organisation;
- To ensure that monitoring system uncertainties are maintained within the meter’s specification the frequency of calibration should be at least once every five years, or earlier if this is recommended by the manufacturers’ instructions;
- Metering should be tamper-proof;
- Evidence of the integrity of monitoring arrangements would normally be inspected as part of any Audit.

The uncertainty (error band) associated with the metered or derived values of all energy inputs and outputs must be determined. Uncertainties may be based on the meter manufacturer’s specifications, or on accepted standards. Calculation of the uncertainty must take into account all components of the measurement (e.g. the sensor(s) or measuring element(s), transducer, transmitter, and integrator or recorder). In addition all metered or derived energy inputs and outputs must be checked to detect bias (errors) in the recorded values. All calculations of uncertainty and checks for bias must be fully documented. Note for most meters for small-Sscale CHP applications this is simply a case of using the manufacturer’s technical data.

The best practice for the maximum uncertainties associated with the measurement of energy flows of different types are as follows:

<b>Fuel inputs, kWh</b>	<b>± 2.0% of reading</b>
<b>Heat metering (hot water heat flow), kWh</b>	<b>Metering to EN 1434:1997. metrological class 2 or 3</b>
<b>Steam heat flow, kWh</b>	<b>± 2.0% of meter range where the average flow exceeds 50% of full range or 4% of reading below this level</b>
<b>Electric power, kWh</b>	<b>± 2.5% of meter reading with metering to EN 61036: 1997 Class 2 or EN 60521: 1995 Class 2</b>
<b>Indirect measurement or calculation</b>	<b>± 5.0% of value</b>

Meters that comply with these requirements in terms of accuracy (uncertainty) shall be deemed to be best practice and no adjustment of their output values is required to take account of uncertainties. Meters that exceed these requirements will require the measurements to be adjusted.

**Statistical Reporting**



## **Biomass CHP / Anaerobic Digestion CHP Call for Proposals**

EU Directive 2004/8/EC requires Member States to submit annually statistics on the production of useful heat and electricity from CHP measured or calculated according to the methodology in the Directive. Applicants in receipt of CHP investment grants must therefore report annually the required statistics to Sustainable energy Ireland who will collate them and submit them to the Commission. SEI will circulate a return annually for completion by recipients of investment grants to collect the necessary statistics.