

---

# Combined Heat and Power (CHP) in Irish Hospitals

## St. Patrick's Hospital Case Study July 11<sup>th</sup>, 2008

Mr. Aidan McDonnell  
Business Manager  
F4energy



# Presentation Outline

---

- **About F4energy**
- **Combined Heat and Power (CHP) Explained**
- **The Combined Heat and Power Project at St. Pats Hospital**
  - **About St. Patrick's Hospital**
  - **Project Steps: Feasibility, Installation, Commissioning**
  - **The St. Patrick's Hospital CHP Plant**
- **Financials of CHP Project**
- **Sensitivity Analysis**
- **The Environmental Benefits**

# About F4energy

---

F4energy was founded in late 2001 by former ESB and Siemens professionals, to design, deliver and maintain Combined Heat and Power (CHP) solutions in the Irish market.

F4energy currently operates approx. 55 CHP plants in Ireland installed in Hospitals, Hotels, Factories, District Heating Schemes and Third Level Institutions.

Clients include Tesco Ireland, NUI Galway, Health Services Executive, Shortts Stainless Steel, Radisson, Marriott, Hilton & Days Hotels



Feidhmeannacht na Seirbhíse Sláinte  
Health Service Executive



# Combined Heat and Power Explained

Combined Heat and Power (CHP) is the Simultaneous production of electricity and useful heat. (steam, air or hot water)

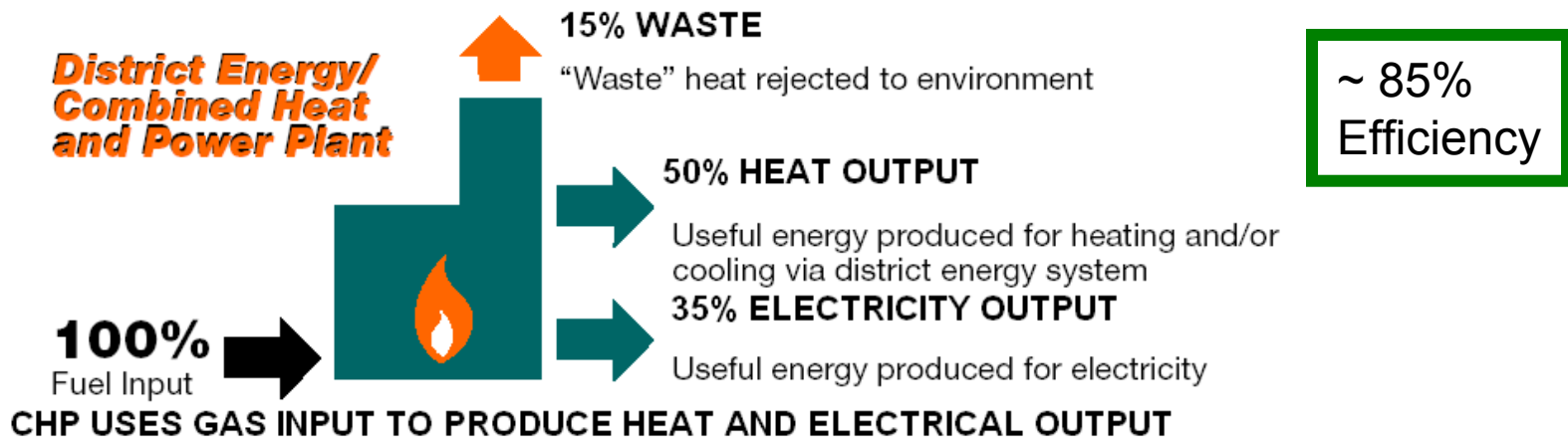
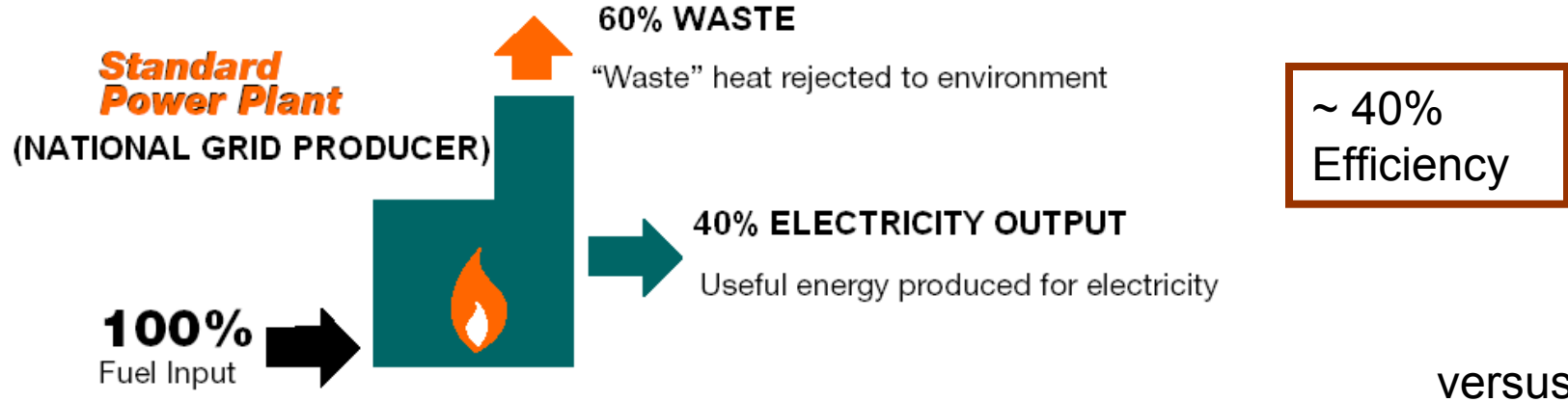

# Combined Heat and Power in Europe

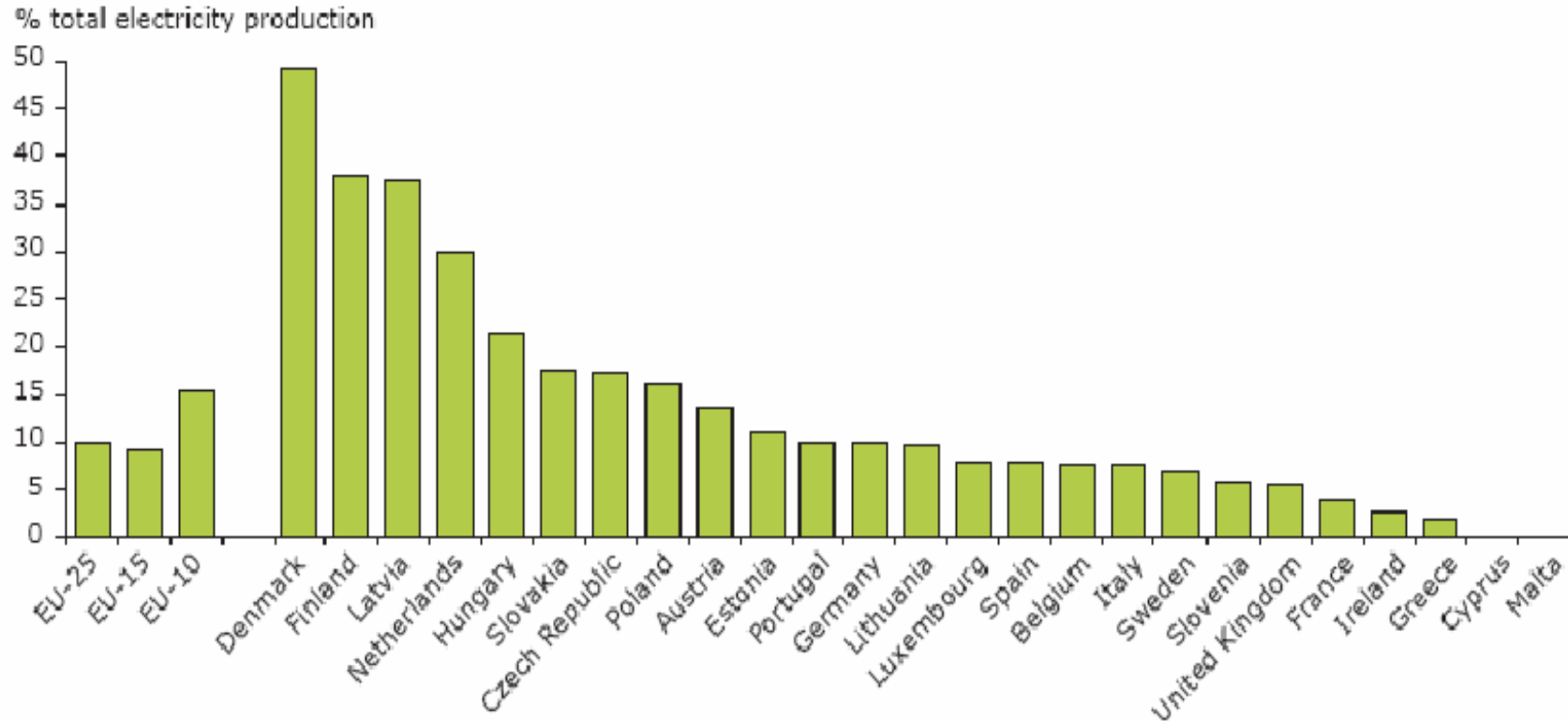

In Europe, 9% of all power production is produced using Combined Heat and Power.....

In Ireland, less than 3% of the nation's power production is produced using Combined Heat and Power

# About St. Patrick's Hospital

---



- *Psychiatric Hospital founded in 1745 by Jonathan Swift*  
(“And showed by one satiric touch /No nation needed it so much....“)
  - *240 Bed Hospital, 2000m<sup>2</sup> Buildings*
  - *Annual Energy Costs in Excess of € 300,000 per annum*
-

# St. Patrick's Hospital Location



# The Combined Heat and Power Project

---

## Why Consider Combined Heat and Power?

> Rising Energy Prices (2005 & 2006, the ESB prices increased by 5% & 16%)

### *STEP 1: Combined Heat and Power Feasibility Study (April 2005)*

A Feasibility Study Report was drawn up by F4energy incorporating:

- i) Review of site's 12 month historic Heat (gas) and Electricity Consumption
- ii) Optimal CHP Plant Output Selection
- iii) Detailed Annual Energy Savings Calculations
- iv) Site Survey
- iv) Choice of CHP Investment Options offered:
  - ▶ Capital Purchase or ▶ Phased Purchase or ▶ Energy Supply Contract

# The Combined Heat and Power Project

## CHP Design Approach:

CHP Plants are available in a wide output range. The Feasibility Study matches the client's Energy Demand Profile with the optimal CHP output range.

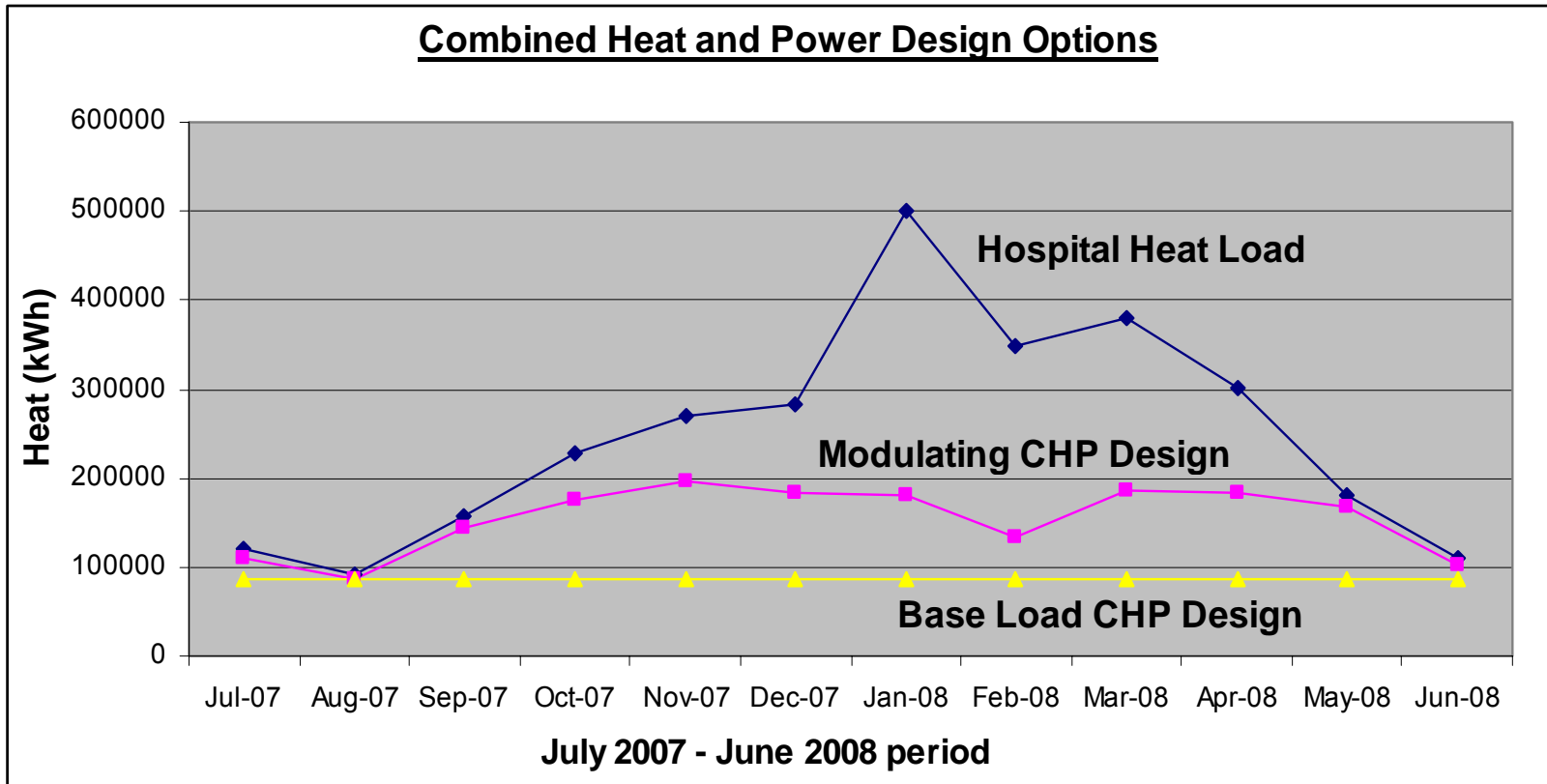

**CHP Plant Selection: Modulating CHP Plant 334kWe/497kWt Max Output**

# The Combined Heat and Power Project

---

***STEP 2: Client Decision, Plant Order, Installation & Commissioning  
(SEI Grants now in place: Application & Approval takes c. 4 weeks)***

<u>Date</u>	<u>Milestone</u>
Apr-05	Combined Heat and Power Feasibility Study
Sep-05	CHP Plant Ordered
Jan-06	CHP Plant Delivered
Feb-06	CHP Plant Commissioned

- Project was prior to SEI Grant Scheme launch
- Project Duration from Order to Commissioning took 20 weeks
- No interruption to Hospital operations during Turnkey Project

# The St. Patrick's Hospital CHP Plant

## Input

Natural Gas  
934kW

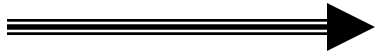

## Outputs

Electricity  
334kW

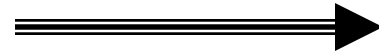

Heat  
497kW



Used for:

- Hot Water
- Central Heating

- Schmitt Enertec (Mercedes) 12 Cylinder Turbo Engine
- Operates 15 Hours Daily X 365 Days
- Producing ~ 90% Hospital Electricity / ~ 80% of the Heat

# The St. Pats Hospital CHP Plant Installation

---

## St Pats LPHW CHP Interface

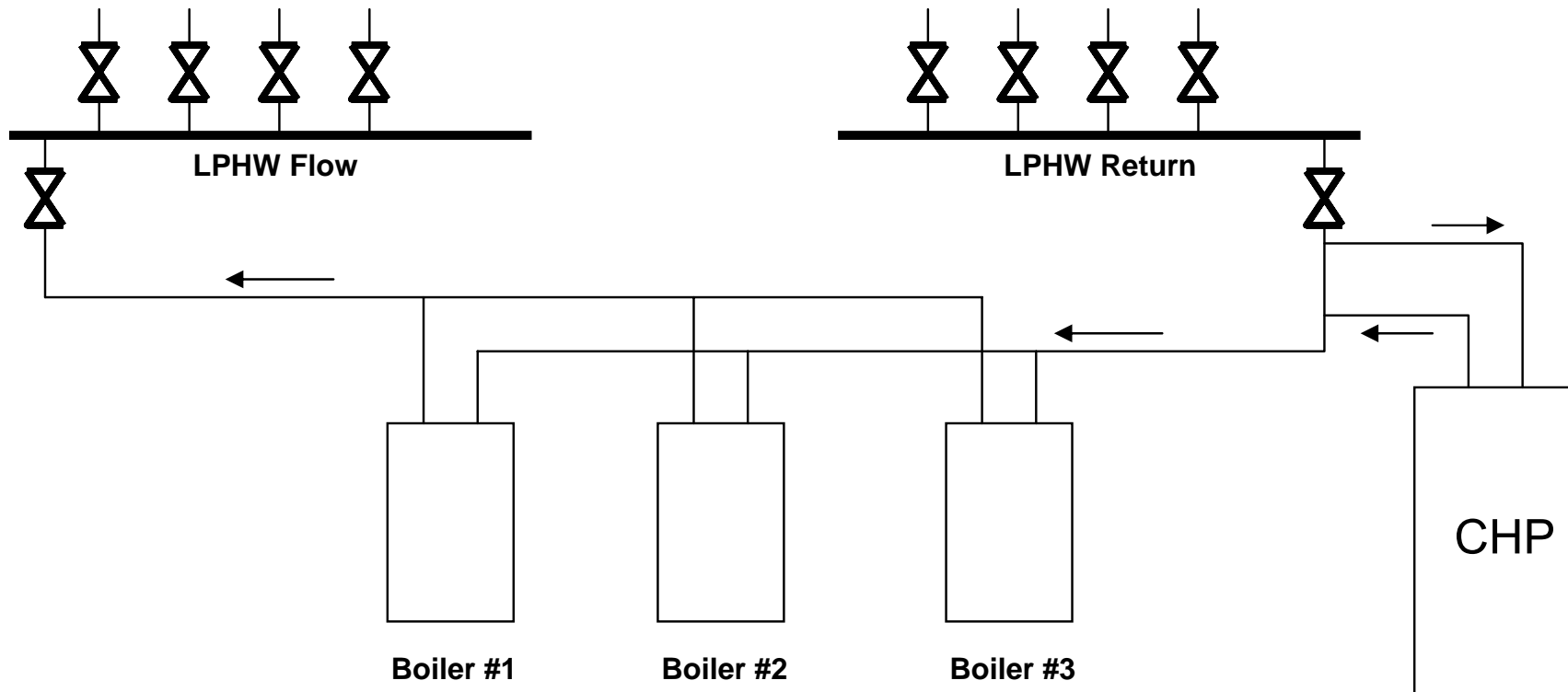

- CHP Plant Connected to Client Boilerhouse Low Pressure Hot Water Header
- CHP Plant Connected to Client Low Voltage Switchgear
- CHP Plant Connected to Client Boilerhouse Gas Supply

# CHP Plant in Situ...

---



# CHP Plant in Situ...



# CHP Plant in Situ...

---



# Performance of St. Pats Hospital CHP Plant

## CHP Electrical Output in Load Follow Mode

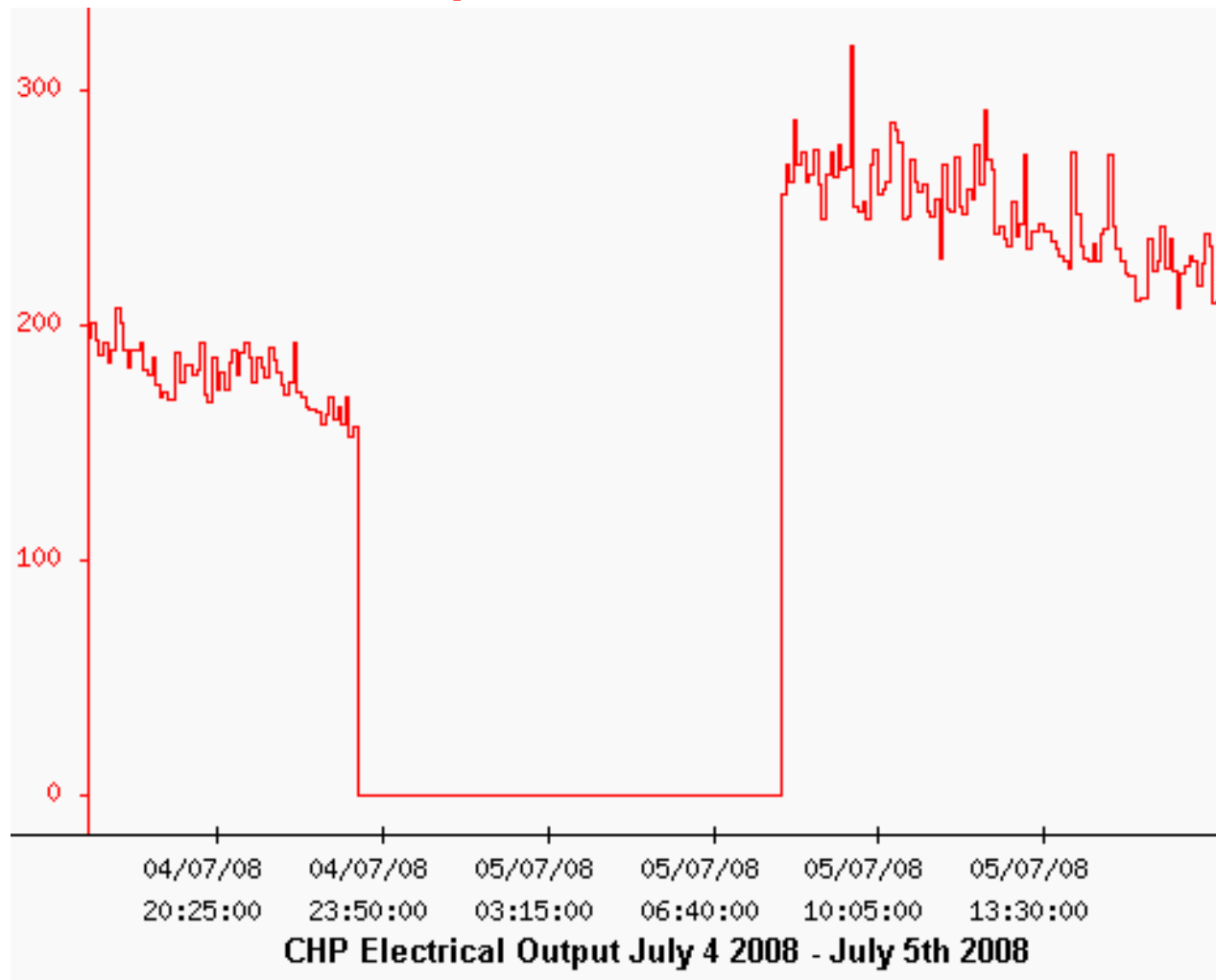

# Performance of St. Pats Hospital CHP Plant

## CHP Thermal Output During Daytime Operations

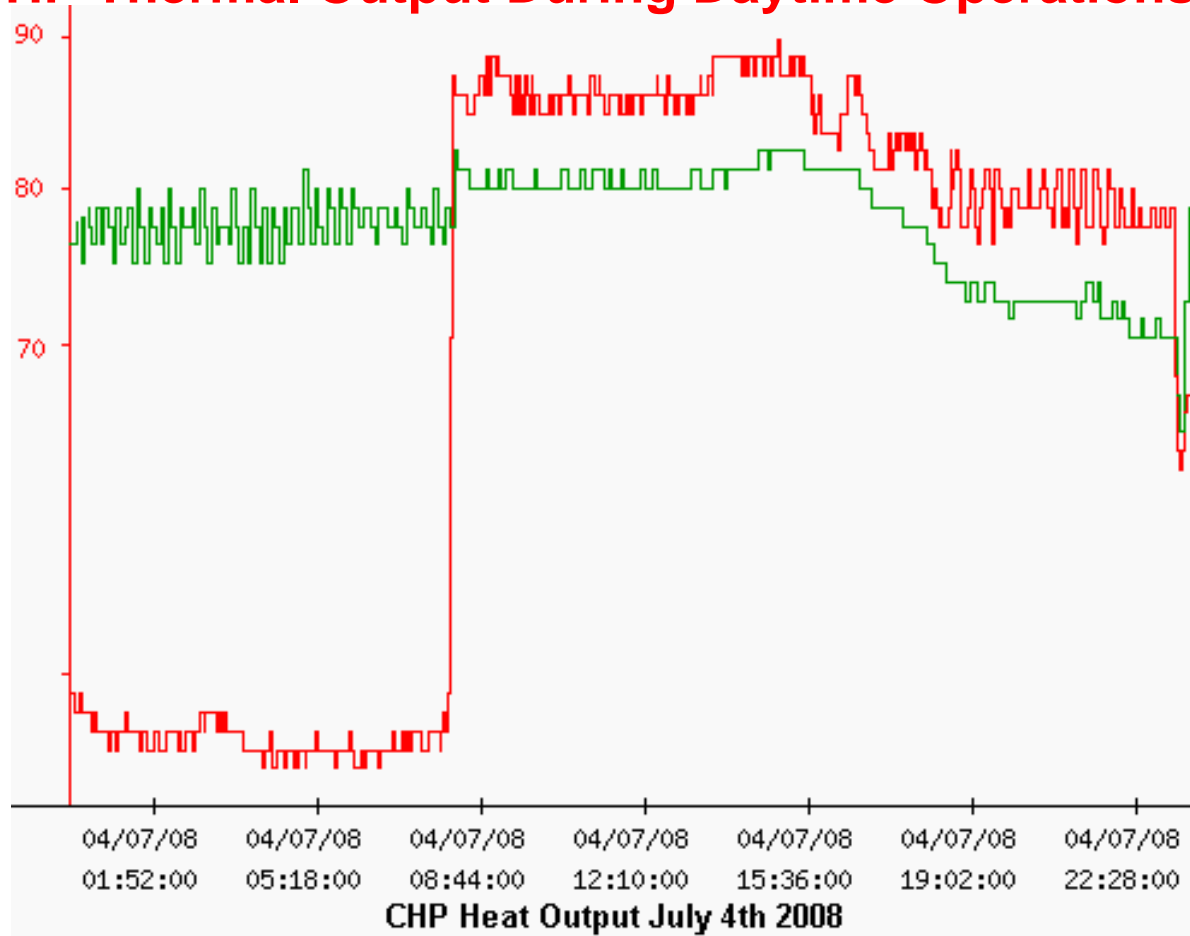

CHP Plant Reduces Output during Low Heat Demand Periods (Summer) & Increases Output during High Heat Demand Periods (Winter)

# Financial Performance of St. Pats Hospital CHP Plant

---

**Annual Energy Cost Savings July 2007 – June 2008: €101,806**

CHP Plant Cost Savings Summary Statement		
	Annual Output <u>kWh</u>	Total Cost Savings <u>€</u>
Value of CHP Electricity Produced	1,396,650	€173,233
Value of Useful CHP Heat	1,844,197	€76,073
<b>Less</b>		
Cost of CHP Gas Consumed	3,990,429	-€131,684
Cost of CHP Maintenance (5,272 Operating Hours)		<u>-€15,816</u>
<b>Net Annual Cost Savings with CHP Plant at St. Pats Hospital</b>		<b><u>€101,806</u></b>

- **CHP Plant Annual Cost Savings have increased by 30% since 2006**
- **Generated investment payback in less than 4 Years BEFORE SEI GRANT**
- **5,272 Annual Operating Hours = 96% Plant Availability in 07/08**

# Sensitivity Analysis + 10% Energy Price Increase

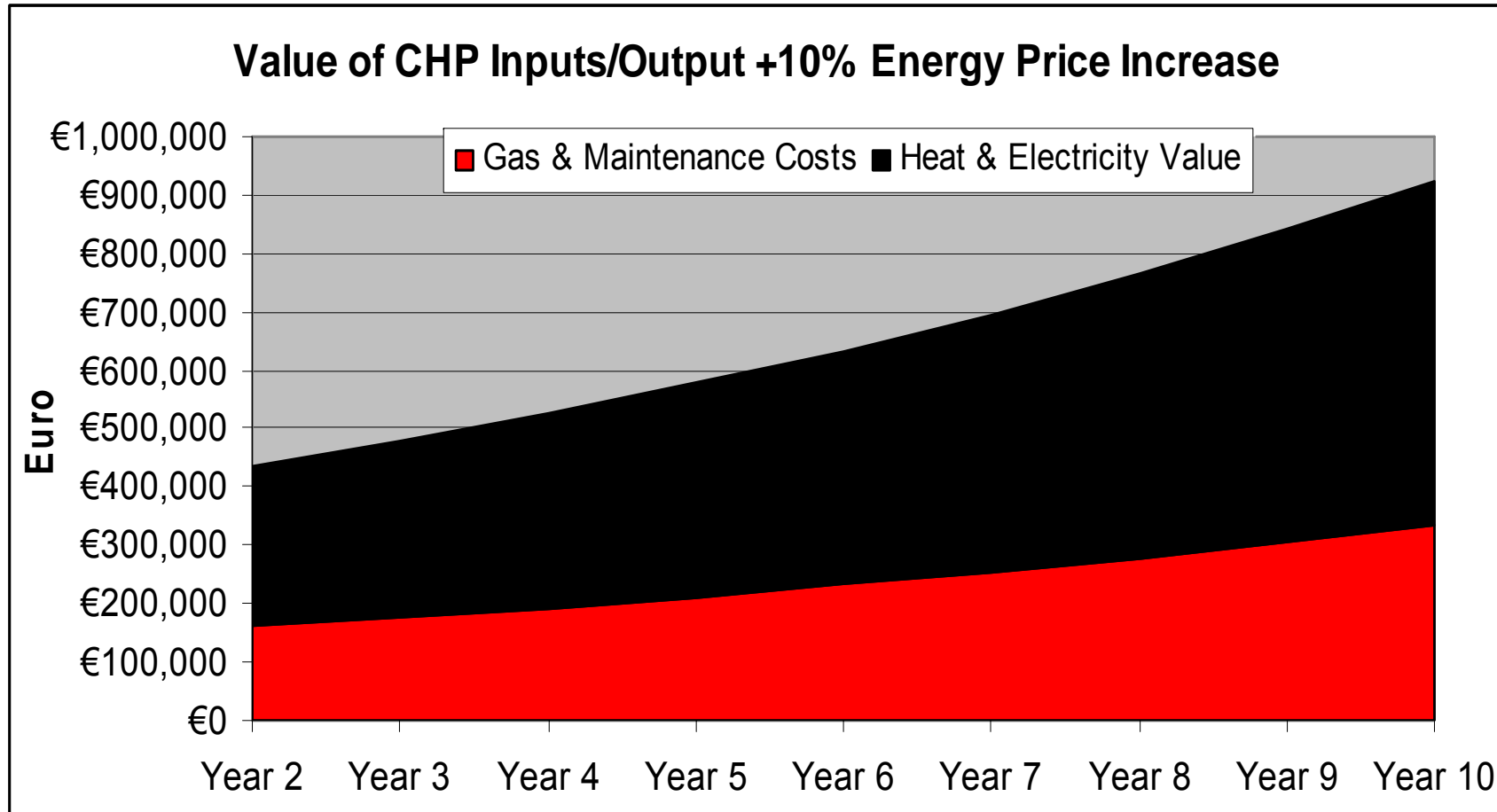

# Sensitivity Analysis + 20% Energy Price Increase

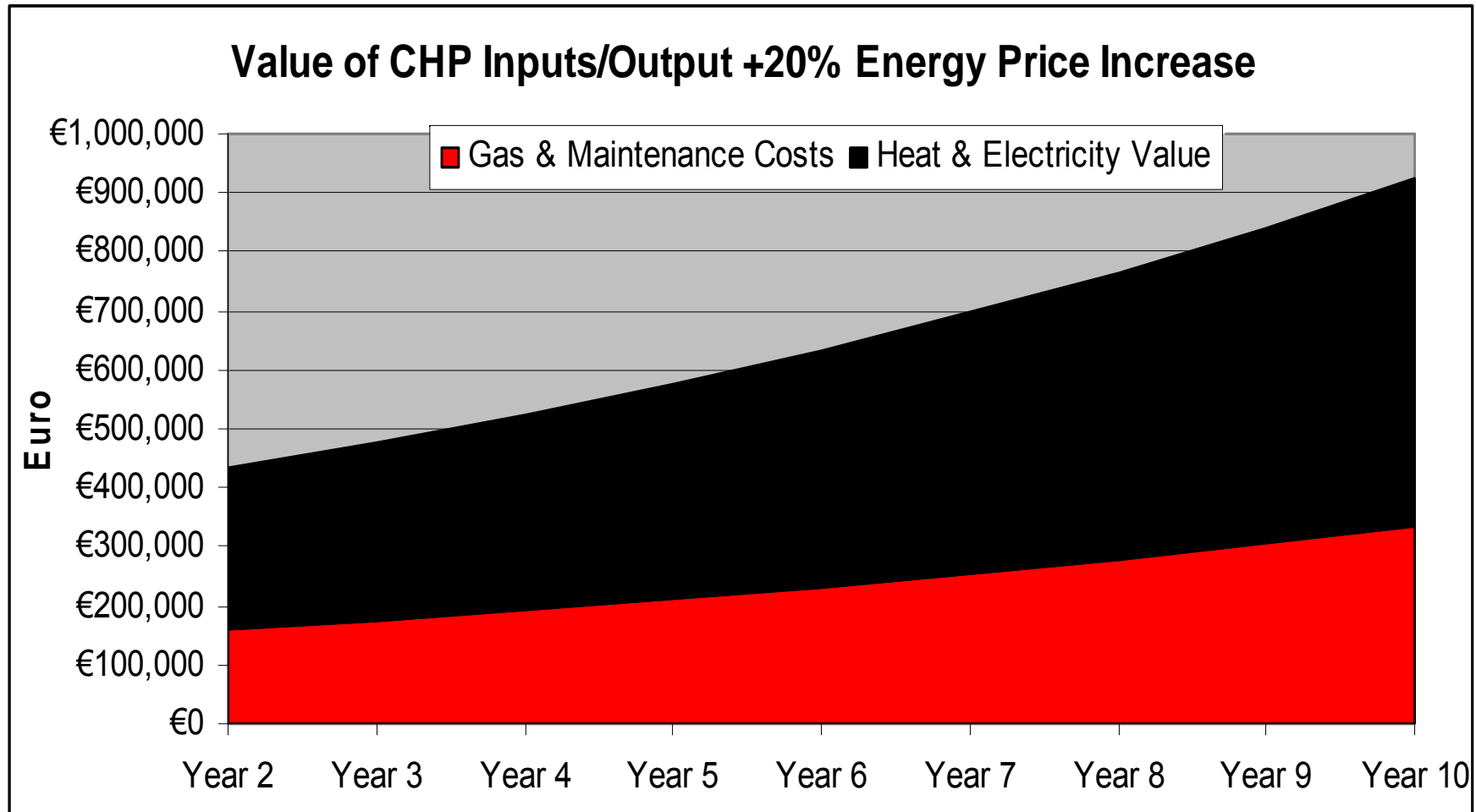

# Sensitivity Analysis – Energy Savings Vs Price Changes

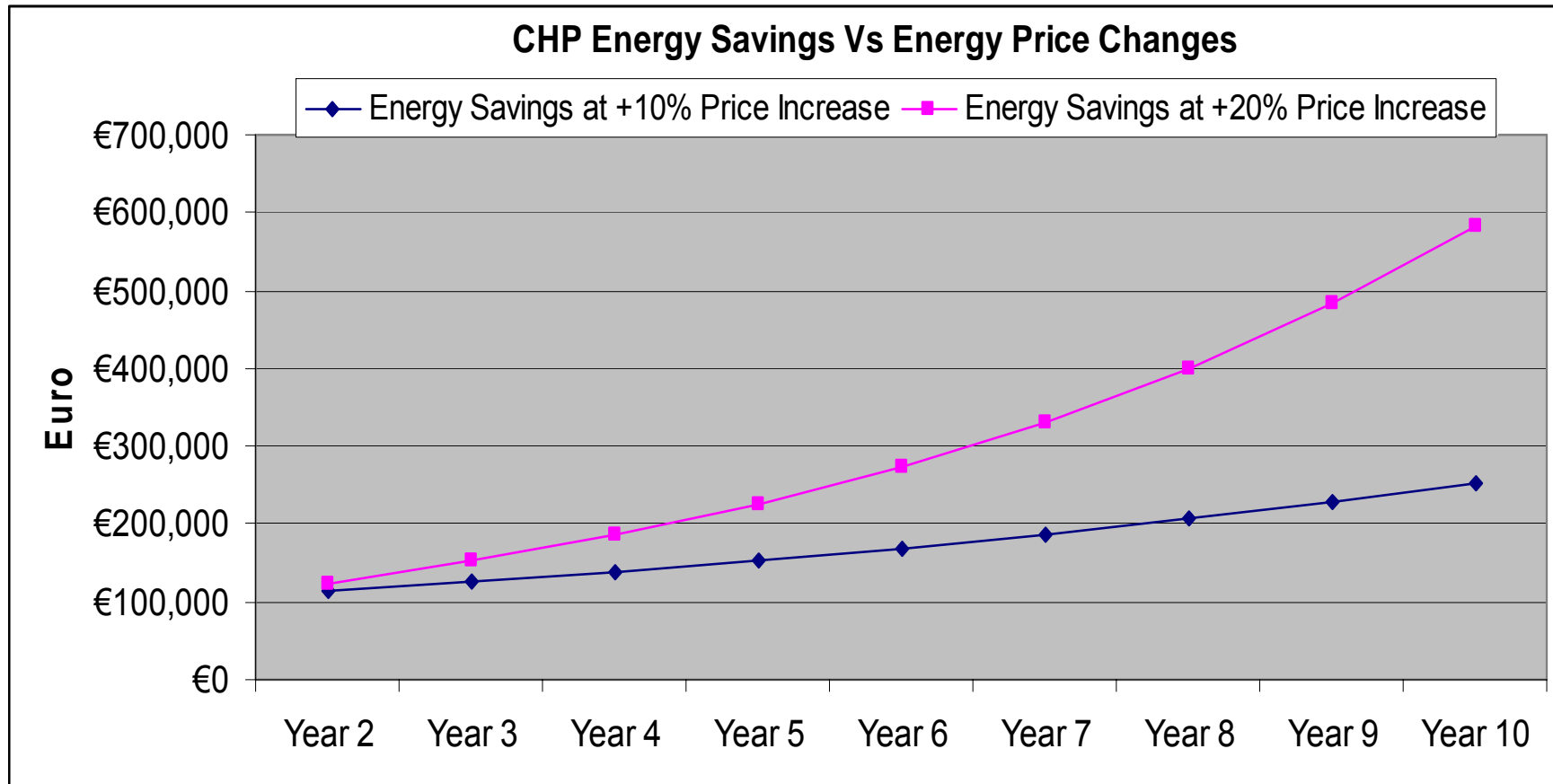

- Annual Energy Savings Growth from €100k – €500k per annum over 10 Years
- Key Financial Success Factor is the ‘Spark Gap’ – Gas Vs Electricity Price

# The Environmental Benefits

---

By displacing national grid electricity, the Days Hotel CHP plant reduces the site's carbon emissions by ~ 500 TONNES CO<sub>2</sub> yearly.

The Equivalent of Removing 130 cars off the Road EVERY YEAR  
Or  
Planting 600 TREES EVERY YEAR!

(Source: Carbon Trust)

Thank You For Your Time

