

Options for the Development of Wave Energy in Ireland

A Public Consultation Document

November 2002

MARINE INSTITUTE

SUSTAINABLE ENERGY IRELAND



Your Plan - Your Future

The Marine Institute and Sustainable Energy Ireland are jointly undertaking this consultation exercise with a view to building a consensus around a strategic approach to wave energy development in Ireland.

Views and comments should be submitted to:

Wave Energy Consultation,
Sustainable Energy Ireland,
Glasnevin,
Dublin 9

Email: wave@sei.ie

Further information is available on the following web sites:

www.marine.ie

www.sei.ie

This consultation exercise will run from November 7th 2002 to
February 28th 2003.

TABLE OF CONTENTS

1	<i>Introduction</i>	1
1.1	Background	1
1.2	Context	1
1.3	Consultation Exercise.....	3
2	<i>The Resource</i>	5
2.1	Wave Energy	5
2.2	The Irish Resource in the Global Context	5
3	<i>Wave Energy Conversion Technologies</i>	9
3.1	Introduction.....	9
3.2	Shoreline/Nearshore Devices.....	9
3.3	Floating Devices.....	10
3.4	Lessons Learned from Device Development.....	11
4	<i>Wave Energy Research and Development</i>	13
4.1	International Experience.....	13
4.2	The Irish Experience.....	15
5	<i>Strategy Options</i>	19
5.1	Option 1	19
5.2	Option 2	22
5.3	Option 3	24
5.4	A National Wave Energy Research Programme to build up niche expertise in targeted areas.....	25
5.5	Generic Studies and Supporting Measures	26
5.6	Development of a field test facility	30

Appendix 1. Wave Energy Conversion Technologies

Appendix 2 International Experience in Wave Energy Development

Executive Summary

The potential for development of wave, ocean current and tidal energy is the subject of growing international investigation. This document focuses on the status and development potential of wave energy in Ireland. While recognising that this technology is not in a position to contribute to national renewable energy targets within the Kyoto timeframe, it is oriented towards the longer term prospect of Ireland becoming a world-leading developer and manufacturer of the technologies that will enable the harnessing of ocean energy resources.

In terms of potential usefulness, the wave climate off the West coast of Ireland is one of the most favourable in the world. The development potential in respect to second generation floating devices, moored offshore, is very significant with the practicable wave energy resource estimated at more than 6000MW.

At present there is no well- established wave energy industry anywhere in the world. There is a potential to create such an industry in Ireland to construct converters for use here, as well as providing technology and converters for export. The premise of this consultation document is that a viable Irish wave energy technology could be achieved with significant investment.

Ireland has developed considerable core expertise in the field of wave energy research and development and there has been significant progress in the development of a number of promising converter types by commercial groups. Existing R&D Programmes available for wave-device development are limited and are not programmatically focused to deliver strategic and targeted objectives of the scope and scale necessary to create a world-leading wave energy industry in Ireland.

In developing a strategy for the development of wave energy technology in Ireland three sets of options/approaches are outlined.

Option 1 -

To become a technology leader in the field of ocean energy by committing to a significant development programme for ocean wave and tidal energy.

Option 2 -

To provide Ireland with the means to utilise the Irish wave resource and develop an exportable core of research excellence.

Option 3-

To maintain a watching brief in the field of wave and tidal energy.

The Marine Institute and Sustainable Energy Ireland, with their separate and complementary mandates for the development of Wave Energy, are jointly undertaking this consultation exercise which will run from November 7th 2002 to February 28th 2003. The ultimate aim is to support and inform the development of a National Strategy for Ocean Energy of which wave may be an important component. The views and comments of interested parties are sought with a view to building a consensus around a strategic approach to wave energy development in Ireland.

1 INTRODUCTION

1.1 Background

Internationally, the major effort in exploiting renewable energy sources has focused on solar and wind resources. If significant resources are directed at ocean energy research, it is conceivable that techno-economic solutions to the problems of harnessing ocean wave and other energy sources will emerge. In that event, given our prime location with respect to an abundant ocean energy resource, and the relative proximity of urban and industrial energy consumers, Ireland is likely to be a user of these technologies when economically viable wave energy systems are available.

For wave energy to be in a position to significantly contribute renewable energy to Ireland's energy demand in the decades beyond 2010, it will need to be at the same level of maturity that offshore wind energy is at currently. This would mean that numerous pilot plants were deployed in the ocean environment proving that the technology is viable, that the cost of large scale deployment is reasonably certain, and that other countries have included the technology in their renewable energy targets.

A critical decision is whether Ireland should seek to become a leading manufacturer and exporter of such converters or be an importer of, and customer for, engineered ocean energy extraction systems. The example of the Danish experience in the area of wind energy technology and systems presents itself as a model for what Ireland might achieve in the field of wave energy. The premise of this consultation document is that viable wave energy technology could be achieved with significant investment.

1.2 Context

This document summarises the status of wave energy development and the potential for its exploitation in Ireland. While recognising that this technology is not in a position to contribute to national renewable energy targets within the Kyoto timeframe, it is oriented towards the longer term prospect of Ireland becoming a world-leading developer and manufacturer of the technologies that will enable the harnessing of ocean energy resources. Its preparation is timely, coinciding with the launch of the EU 6th Framework Programme, the implementation of the National Development Plan and the developing activities of Sustainable Energy Ireland and the Marine Institute.

The Technology Foresight Report (ICSTI, 1999) identified wave energy as one of the strategic technologies where Ireland had abundant untapped resources and where, for strategic, energy and commercial reasons, research and development with a view to exploitation should take place.

Important policy initiatives bearing on the contribution that wave power can make to renewable energy supply in Ireland are:

- The **Green Paper on Sustainable Energy**, which proposes increasing the percentage of Total Primary Energy Requirement derived from renewable resources from 2% in 2000 to 3.75% in 2005, and the percentage of electricity generated from renewable resources from 6% in 2000 to 12% in 2005, including an extra 500MW of installed capacity.
- The **National Climate Change Strategy**, which outlines Ireland's strategy to meet its commitments under the Kyoto protocol to reduce growth in greenhouse gas emissions.
- The **National Development Plan** which has allocated €67m for alternative energy by upgrading the capacity of the electricity grid to accommodate renewable energy, and supporting additional sources of renewable energy and encouraging new entrants to the renewable energy market.

The targets in the Green Paper on Sustainable Energy, for the installation of 500MW of electrical capacity based on sustainable sources in the period 2000-2005, will largely be realised through wind energy. The principal mechanism for achieving this target is the process of Alternative Energy Requirement (AER) competitions, although significant contribution is being made by at least one company operating outside the AER mechanism.

The deployment of renewable energy technologies needs to be considered in an appropriate timeframe since they are at differing stages of development. An appropriate framework would be:

- short term to 2005;
- medium term to around 2010;
- and long term, the decades beyond 2010.

Short term to 2005

The Green Paper targets are relevant in the short term - 12.39% of electricity generation from renewable energy sources and an additional 500 MW installed between 2000 and 2005. The technologies that have been supported in Ireland to date are those that are considered the most mature and thus the most likely to successfully and economically contribute towards the Green Paper targets. These include on-shore wind energy, small-scale hydro, and landfill gas. These technologies are technically proven in Irish conditions and, with the exception of small-scale hydro, operate at prices that are near to competitive with traditional fossil fuel powered energy. Looking beyond the near term 2005 target, the potential for these technologies will be resource constrained.

Medium term to 2010

A number of other technologies have reached a promising stage of technical development but are farther from commercial viability. Those with potential for application in Ireland include biomass steam-cycle CHP, biogas anaerobic digestion,

and offshore wind energy for the provision of grid -connected electricity. While not likely to contribute significantly to the 2005 target, these technologies could provide a significant contribution toward the medium term 2010 target of 13.2% of electricity generated from renewable sources, as articulated in the EU Directive on the promotion of electricity produced from renewable energy sources (RES)¹. They will however be required to meet more onerous targets expected beyond 2010.

Long term beyond 2010

Other technologies, that convert resources in which Ireland is particularly wealthy, are still at the research and development phase. These include biomass from energy crops and ocean wave and tidal energy that will be needed in the longer term to meet the much more challenging environmental targets expected beyond 2010. Many of the technical difficulties around working in the marine environment that ocean wave and tidal technologies will face are also relevant to offshore wind energy.

While the price of energy from renewable sources will remain competitively disadvantaged until such time as the environmental effects of using fossil fuels is reflected in the price of energy from traditional sources, it is clear that there is an inexorable process in train, both internationally and in Ireland, which will lead to the increasing utilisation of technologies which exploit natural and sustainable sources of energy. As the country with the best combination of high wave power levels and deep water close to the coast, Ireland has a natural advantage in the exploitation and development of wave energy.

1.3 Consultation Exercise

This consultation document is presented in the context of the developing R&D activities of Sustainable Energy Ireland and the Marine Institute. The objective is to elicit discussion and feedback on the approach to the development and utilisation of wave energy in Ireland. The ultimate aim is to support and inform the development of a National Strategy for Ocean Energy of which wave may be an important component.

While the potential for development of ocean current and tidal energy is acknowledged, this document focuses on the status and development potential of wave energy.

The Marine Institute and Sustainable Energy Ireland will jointly undertake this consultation exercise. Both agencies have separate and complementary mandates for the development of wave energy:

- Sustainable Energy Ireland has recently launched a research, development and demonstration programme aimed at stimulating the deployment of

¹ Directive 2001/77/EC on the promotion of electricity produced from renewable energy sources in the internal electricity market

renewable energy technologies which are close to market, and at assessing the potential and supporting the development of technologies with prospects for the future. In this context, wave energy is considered a prospect for the future and therefore eligible for support under the programme. SEI's mandate also includes the advancement of other policy initiatives with respect to the development and deployment of renewable energy.

- The Marine Institute's mandate is to stimulate the development of commercial technologies, which exploit and add value to Ireland's marine resource. In this context the Institute supports the development of the R&D infrastructure and expertise for wave energy development and through its industry R&D programme invests in the early stage development of specific wave energy devices.

This consultation exercise will run from November 7th 2002 to February 28th 2003. The views and comments of interested parties are sought with a view to building a consensus around a strategic approach to wave energy development in Ireland.

2 THE RESOURCE

2.1 Wave Energy

Wave energy is a concentrated form of solar energy. Winds generated by heat differences in the earth's atmosphere transfer their energy to the ocean surfaces. The initial solar power is concentrated in waves which can have power levels of over 1 MW per metre of length at their crest. Wave energy devices extract and convert this energy, using a variety of technologies, into a form from which electricity can be generated. Some converters utilise mechanical energy to process seawater, e.g. for desalination purposes.

2.2 The Irish Resource in the Global Context

Wave power is conventionally rated in terms of the energy flux crossing an imaginary line (the 'wave front', or a contour of stated depth) and has been recorded at many locations.

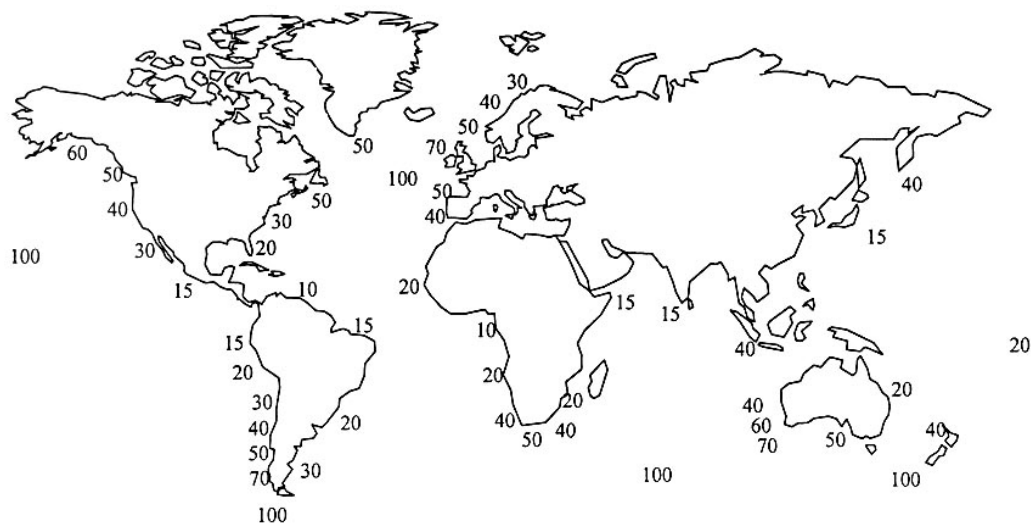

Source: T W Thorpe, ETSU, November 1999

Fig 1 Approximate global distribution of wave power levels (kW/m of wave front)

The exceptionally rich wave power resource of the NE Atlantic is clearly evident in Fig 1, which shows the effects of the prevailing wind circulation, with long-wavelength seas driving towards the west coasts of Ireland and Scotland.

Wave data are now remotely sensed using Synthetic Aperture Radar (SAR) which can provide wave heights to an accuracy of 25mm. During winter in the Northern hemisphere wave heights are the highest in the world.

Jan 1996

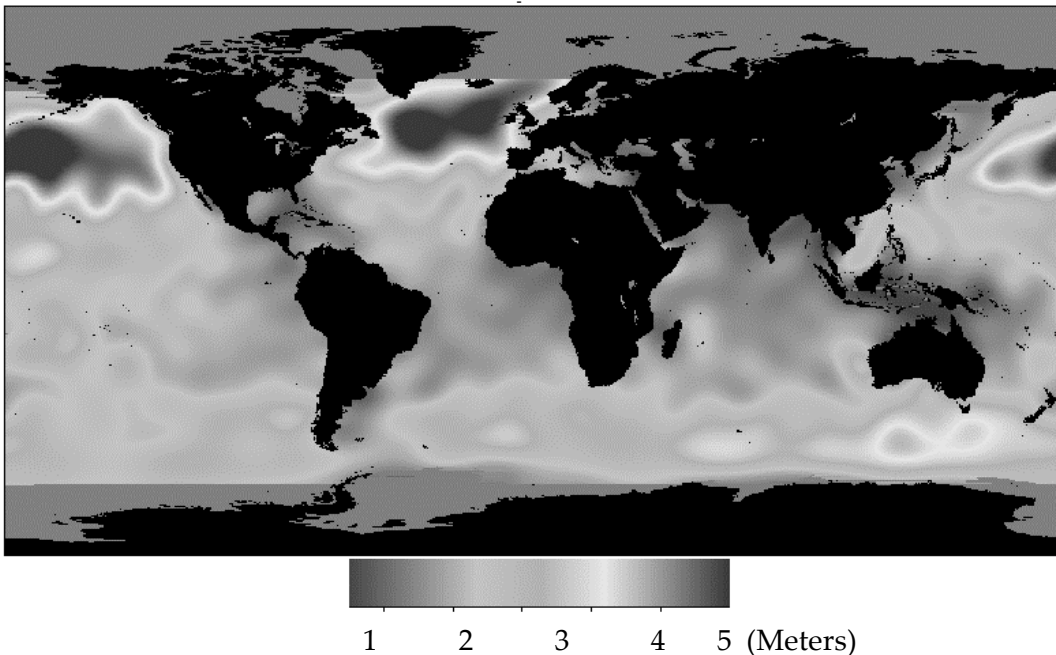

¹ Synthetic Aperture Radar or the Satellite Radar Altimeter ¹ 54° 34' N, 10° 30' W

Fig 2: Global mean wave height (metres), January 1996 **Source: SAR imagery

At other times of the year the situation is reversed and the greatest wave energy is to be found in the Southern oceans -the 'roaring forties'.

However, in terms of potential usefulness, the wave climate off the West coast of Ireland is one of the most favourable in the world and certainly the most conveniently placed. The average annual wave height in deep waters off the Mayo / Donegal coast is over 3.5 metres, with a period of close to 10 seconds. In winter months the figures are much higher. In energy terms, wave power for January regularly exceeds 150kW/metre length. The peak figures for the extreme seas are far higher and more powerful again; the 100-year 'design wave' off the Irish west coast is taken to be 35 metres from trough to crest. In seeking to exploit this potential source of energy, there is therefore an accompanying engineering challenge in designing for such severe conditions.

As they near the shore and the water becomes more shallow the waves begin to lose power due to friction with the seabed. So in energy terms the offshore resource is greater than near-shore, and both are greater than at the shoreline.

Over the past few years a detailed assessment has been made of the wave power along the Irish coast. A development potential of 800MW has been identified at prime sites for shoreline and near-shore devices. The development potential in

respect to second generation floating devices, moored offshore, is very much greater. The practicable wave energy resource is estimated at more than 6000MW.

3 WAVE ENERGY CONVERSION TECHNOLOGIES

3.1 Introduction

The oil crisis of the 1970's provided the impetus for serious research into wave energy conversion. In recent years threats to the global environment and the need to harness renewable energy sources have re-vitalised interest in the subject. Utilising the experience gained from the offshore oil and gas industry, there is a growing realisation that ocean wave energy conversion may become a practical reality. This changing attitude is reinforced by the success of on-shore wind power.

In parallel the necessary knowledge base has developed greatly. Again this is largely due to the experience of the marine engineering sector in offshore oil and gas exploration and development, but is also the result of improved theoretical understanding of ocean waves and the accumulated experience of 30 years of R&D into wave energy conversion.

A variety of device concepts have been proposed for the utilisation of wave energy over the period. Few devices have been tested in the sea at full scale and only one system can be considered close to full development (utilising the Oscillating Water Column or OWC technology - see below).

While it is technically feasible to construct wave energy converters (WEC's) that will perform efficiently at sea, a number of detailed factors that affect the economics are still unknown, given the lack of operational experience with research prototypes or pilot plants. Tank testing of scale model converters has been carried out in several countries and a number of numerical models based on mathematical analysis have been developed. Further tank testing and mathematical modelling is required; validating these will require full size prototypes to be tested at sea. Component reliability and survival of the devices in storm wave conditions can only be determined in full-scale trials.

From the many theoretical solutions that have been proposed, the range of alternatives is converging on a small number of promising options.

3.2 Shoreline/Nearshore Devices

The first generation converters are seabed mounted and can be on the shoreline or in the nearshore region. The bathymetry of the West Coast of Ireland offers the typical depths of less than 20m required for these converters, in many places less than 500 metres from the shoreline. The construction techniques to be adopted for these converters are similar to those used in standard maritime civil engineering structures, with site-specific variations to improve performance.

A number of these converters have been constructed, in Norway, India and Japan, but for a variety of reasons little operational experience has been gained.

Closer to Ireland, a small experimental system was constructed by Queen's University, Belfast at Islay, Scotland and operated for more than ten years up to 1996. This unit was a small prototype rated at 70 kW and provided a good research plant for testing Wells turbine generators.

More recently two larger scale first generation converter projects have been initiated:

1. Pico Island, Azores - a 500 kW plant was constructed in a natural gully. This converter consists of a concrete chamber constructed in-situ behind a temporary rock-fill cofferdam. There have been a number of problems during construction with damage occurring to the concrete chamber during un-seasonal storms in 1996. As a result of these events the completion has been delayed.
2. Limpet - a shore based unit, constructed by Wavegen Ltd. in conjunction with Queen's University Belfast, on the island of Islay, Scotland. The system consists of three inclined concrete tubes each 6 metres wide constructed on a specially prepared sloping rock face at the coastline. The currently installed capacity of the combined system is about 160 kW and the generating system uses biplane Wells turbines. The construction started in late 1998 and the system came into operation in November 2000.

The operational results of these pilot plants have not been made available and so it is difficult to make firm predictions of the reliable electrical output. While OWCs have proven that wave energy can successfully be converted to usable energy, the economics of such devices are not promising and there are few sites suitable for development. While some developers, such as Energetec (Australia), are promoting near-shore devices, there is limited development potential for shoreline and near-shore devices and the emphasis in future development will be focussed on floating offshore devices.

3.3 Floating Devices

Offshore devices exploit the more powerful wave regimes available in deeper water. In order to be able to efficiently extract the energy from the waves, the devices need to be at or near the surface and therefore require flexible moorings and electrical connectors. A wide range of prototypes and designs for floating converter systems have been proposed by developers. These are outlined in greater detail in Appendix 1.

These units are still at the early development stage but a few could be ready for sea trials in the short / medium term. The reliability of moorings and interconnections where large numbers of converters are involved is critical. In order to absorb reasonable amounts of wave energy however, the point absorber must undergo large displacements, which can pose particular difficulties for power take-off systems. The majority of these types of device, either mounted on the seabed or using the mooring

system for reaction, incorporate a float performing a pumping action. These mechanical pumping systems suffer from the “end-stop” problem where large destructive forces can be experienced during extreme storms when the pumps may reach the end of their travel violently, with a resulting failure of the systems.

Examples of these second generation converters are the DWP Float, the Technocean, Hose-Pump Buoy, the McCabe Wave Pump, the B2D2 and the WaveBob. The IPS Buoy (and its successor Sloped IPS) is however the only example of this mechanical-type converter where the end stop problem has been elegantly solved as this is a hybrid OWC type converter. Floating OWC converters such as the Backward Bent Duct Buoy (B2D2) and SPERBUOY in general do not suffer from this severe mechanical limitation during extreme events since the power take-off system is not directly coupled to the motion.

3.4 Lessons Learned from Device Development

Among the lessons learned, and conclusions drawn, from international experience to date are:

- **The next step in successful development is to move the technology from the lab to the field.** A large body of research knowledge has been developed in Ireland and internationally, and a number of projects are moving towards the pilot scale test stage. Vital experience, and developmental advantage, will be gained through the deployment and operation of full-scale prototype devices.
- **Transfer of knowledge is a key factor in successful development.** This requires the continued development of nodes of specialist expertise and knowledge transfer mechanisms to support the exchange of information in a way that respects commercial confidence.
- **Public finance should be used to leverage private finance.** Several wave energy devices are at an advanced stage and show some potential. However, because of the relatively high initial costs and some of the credibility problems facing wave energy, gaining adequate financial support for pilot developments has been difficult and time consuming, delaying the deployment of these schemes. Financial support from the public sector is needed to prime and accelerate the commercial development of wave conversion systems.
- **Site selection is critical.** The site should be selected not just for its available wave energy, but also for accessibility and grid connection. Full development will entail highly site-specific characteristics and will require the necessary permissions. This may be an onerous procedure for pilot-scale developments so the provision of a serviced site for device testing can facilitate the development of the technology.
- **Good project management is required from people with relevant experience.** Good project management and relevant team experience are essential. Inclusion of commercial funding tends to bring in the advantages

of private sector disciplines –focussed attention on costs and returns and adherence to schedules and deliverables. However, it also brings in private sector demands for speedy returns, which could lead some devices to be deployed before they have been adequately tested and proven.

- **Independent assessment of devices is crucial.** There is a need for a panel of well-informed independent assessors to support project evaluation. Feasible technical and economic milestones should be incorporated into R&D projects from the start.

4 WAVE ENERGY RESEARCH AND DEVELOPMENT

4.1 International Experience

R&D on wave energy is underway in several countries world-wide, even in countries with poor wave energy resources (e.g. Sri Lanka and Mexico). This report will concentrate on European countries. Details of national programme activities are provided in Appendix 2.

Denmark

Wave energy is still perceived in Denmark as being at the R&D stage, with one concept expected to progress to the demonstration stage within the next few years. Denmark has tried to develop an indigenous wave energy industry, with a view to dominating that technology in a similar way to its achievements in wind. However, it has been hampered in this by its poor wave energy climate and a lack of good in-house ideas. Following the recent change of Government and the resulting uncertainty about the future of the renewable energy programme in Denmark, its wave programme has been suspended indefinitely.

France

With its heavy investment in nuclear PWR technologies, France has showed little interest in wave energy. However, there are signs that this might be about to change. A progressive renewable energy price support policy has recently been instituted for wind and other renewable energy technologies and increased interest has been shown in the International Energy Agency (IEA) Implementing Agreement on Ocean Energy Systems.

Norway

Wave energy in Norway is classified to be at the research stage and at present too expensive to be developed (In contrast, Norway has ample hydro and wind resources capable of generating electricity at ~ 0.03 €/kWh). Wave energy is considered to be competitive in niche markets (e.g. diesel generation in isolated coastal areas (NVE, 1998). Other niche markets are:

1. water pumping in fish farming
2. navigation buoys
3. ship propulsion
4. power generation for oil and gas offshore installations using remote wave energy converters

Portugal

The Portuguese Government has started to take effective measures to establish wave energy within Portugal:

- These have been instrumental in attracting the Archimedes Wave Swing (AWS), being promoted by a Dutch commercial venture, to Portugal through continued political support for the project.

- The Government has recently announced that wave energy projects would receive enhanced prices for electricity delivered to the grid. Early estimates are for an initial allocation of 30 MW and a premium price of 0.25 €/kWh.

UK

The current UK programme concentrates on industry led projects, reviewed by a panel of experts, establishing clearly defined development and economic targets.

To date, the DTI Programme has funded work with several contractors:

- Wavegen, for the development of the LIMPET and "Project X"
- Ocean Power Delivery for the development of the Pelamis
- University of Edinburgh for the development of the Sloped IPS Buoy
- Ove Arup for a technical review and technology transfer relating to wave energy (Arup, 2000)
- Durham University for a comparative study of linear generators and hydraulic systems.

European Commission

A first step to improving collaboration between wave energy developers, academia and the electricity industry was taken by the European Commission in 1999 with the formation of the European Thematic Network on Wave Energy under the 5th Framework Programme. The Network was launched in 2000 and its activity is focussed in six main areas

- **Co-operation with the power industry.** To induce a long-term co-operation with the power industry (e.g. electricity utilities, wind power industry) in order to involve the utilities and to learn from the experience of the wind power industry.
- **Social, planning and environmental impact.** To identify the planning, legal and commercial barriers and the social benefit, energy and environmental impact arising from the expected development of wave energy schemes. To create recommendations for their development.
- **Financing & economic issues.** To evaluate the financing, economics and monetary issues for developing wave energy schemes.
- **R & D on wave energy devices.** To identify the current status of wave and tidal energy device development. To determine the technical barriers to the commercial development of these devices at different time scales. To develop a standard for assessment of existing and new devices. To develop a Strategy for Development and an Action Plan
- **Generic technologies.** To co-ordinate activities on generic technology issues concerning the utilisation of wave and tidal/current energies, so as to facilitate the exchange of experience and the transfer of knowledge. To promote knowledge and technology transfer from the offshore industry and coastal engineering. To promote studies on these issues.
- **Promotion of wave energy.** To promote wave energy as a renewable source of energy, capable of significant contribution to electricity production in Europe in the near future. This promotion will use several media in order to reach different areas of industry and society.

4.2 The Irish Experience

At present there is no well- established wave energy industry anywhere in the world. There is a potential to create such an industry in Ireland to construct converters for use here, as well as providing technology and converters for export.

Ireland has developed some core competencies in the field of wave energy research and development. Leading groups that have been involved with international projects for a number of years include the Hydraulics and Maritime Research Centre Group, University College Cork, the Queen's University Belfast Group, and more recently the Air Turbine Group at the University of Limerick. These projects include the Wavenet, the EU Thematic Network on Wave Energy and the IEA Implementing Agreement on Ocean Energy Systems.

A summary of the capabilities of these groups is as follows (Fig 3):

- The Hydraulics and Maritime Research Centre, University College, Cork: Long-established expertise in the hydrodynamics of wave power devices
- Department of Electrical Engineering, University College, Cork: expertise in grid connectivity and power quality issues
- Queens University, Belfast: Mechanical and Electrical Engineering & OWC wave energy devices.
- University of Limerick: the Mechanical and Aeronautical Engineering Department has developed specific expertise in Turbine and Power takeoff systems and Computational Fluid Dynamics.

Additional specific expertise includes the Department of Electrical Engineering, NUI Maynooth (Software Control Systems) and the Department of Mechanical Engineering, TCD (Hydraulics and mechanical engineering)

The Marine Institute has actively supported the investigation of wave energy development and has funded a number of studies on the resource potential and on technologies to exploit this:

- Strategic Review of Wave Energy Resource – HMRC, Cork.
- Development of Turbine Technologies for OWC type converters– University of Limerick
- Development of WaveBob -Forest Renewables Ltd., DuQuesne Environmental Ltd.

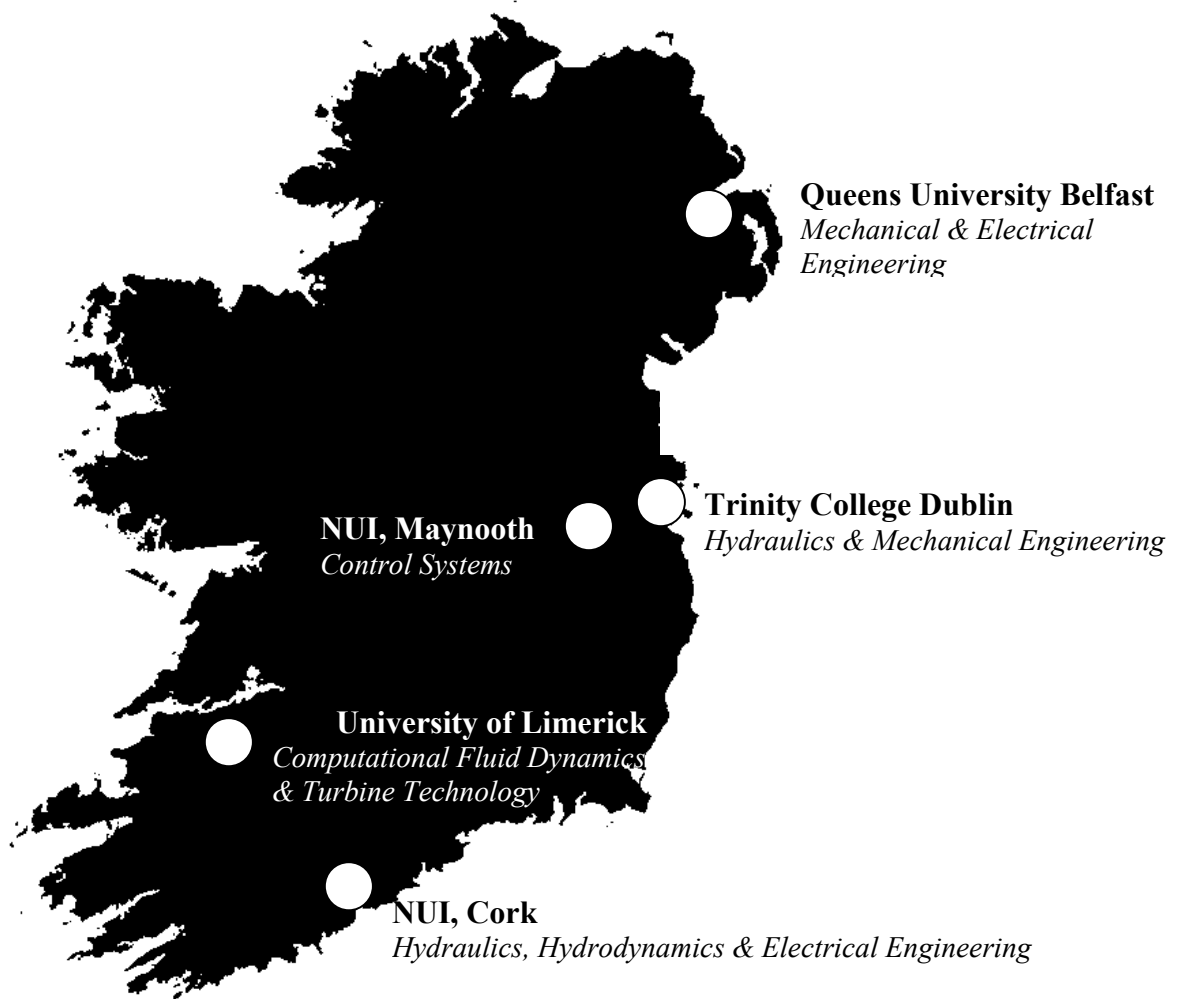

Fig 3. Map of Wave Energy Research Capabilities

In addition Enterprise Ireland have funded R&D on the Backward Bent Duct Device (B2D2) being developed by a commercial company, supported by University College Cork.

Both the Marine Institute and Sustainable Energy Ireland have received proposals for innovative R&D projects, under recent calls for proposals (2002), from a variety of research and commercial interests. These are currently being evaluated.

Private sector interest in this technology has been limited by the same economic realities that have curtailed the development of all renewable energy technologies. Nevertheless, there has been significant progress in the development of three converter types by commercial groups:

- Hydram Technologies Ltd.
- Wavebob Ltd
- Ocean Energy Ltd.

There is a substantial core of industrial experience in Ireland, North and South, to provide the specialist design, engineering and manufacturing capability to realise the development potential which wave energy offers. Relevant companies, in addition to a wide range of specialist engineering, power management, material manufacturing and communication resources, include ESIL and MCS International in the South and Musketeer Engineering and the remaining core of skills in Harland and Wolff in the North.

A variety of funding mechanisms currently exist in Ireland to provide support for R&D on wave energy technologies. These include:

- The Applied (Industry) Marine RTDI Programme managed by the Marine Institute.
- The Renewable Energy Research, Development and Demonstration Programme managed by Sustainable Energy Ireland.
- The Feasibility Grant Scheme administered by Enterprise Ireland.

These programmes are, however, limited and are not programmatically focussed to deliver strategic and targeted objectives of the scope and scale necessary to create a world-leading wave energy industry in Ireland. There are many examples of such targeted programmes, both internationally and in Ireland. The example of Denmark in creating a world-leading industry in wind turbine manufacture is referred to elsewhere in this document. In Ireland the Government has recognised the potential benefits of concerted investment in technology areas deemed capable of delivering strategic benefits to the Irish economy. Recent examples of this include the commitment of €650 million to the support of science and technology in the fields of Biotechnology and Information and Communications Technology, co-ordinated by Science Foundation Ireland, and the €130 million investment in the Digital Hub. The commitment of public funding to support the development of world-class expertise in the field of Ocean Energy technology in Ireland may yield commensurate benefits to the Irish economy.

5 STRATEGY OPTIONS

In developing a strategy for the development of wave energy technology in Ireland a range of options/approaches can be adopted.

5.1 Option 1

Option 1 is focused on the development and deployment of indigenous wave energy technologies with a view to stimulating the development of a world leading wave energy manufacturing sector in Ireland.

There are currently three wave energy concepts being developed by Irish companies. These are either at the conceptual testing or prototype stage. These devices (plus any new ideas) require a range of supports to ensure the successful deployment of an operational pilot plant. In addition resources need to be channelled towards developing a leading edge internationally exportable expertise around ocean energy in Ireland. The research and development centres currently existing should be strengthened and their facilities reinforced. The objective would be to create, in Ireland, a process analagous to the Danish success in wind turbine development, where significant funding was channeled toward the development of wind turbine technology during the 1980s and 1990s, resulting in the establishment of a world-leading manufacturing industry.

Wind Energy - The Danish Experience

For 25 years, the Energy Research Programme in Denmark has provided financial support for use –oriented energy research, and has contributed to the development of technologies that have underpinned energy policy targets.

The objective of the Energy Research programme is to contribute to global sustainable development through expanded use of Danish technology and expertise.

Energy technology is a growth area in Danish industry. Some 60% of the world's wind turbines are manufactured in Denmark. Turbine development continues and systems are becoming cheaper and more efficient. By 1999, wind turbine exports alone, amounted to more than €1.1 bn.

Option 1 - Strategic Intent:

To become a technology leader in the field of ocean energy by committing to a significant development programme for ocean wave and tidal energy.

Target:

- At least one operational indigenous Irish pilot plant is deployed off in Irish waters by 2007.

Strategy:

- Clearly articulated political and policy support for the development of the ocean energy technology.
- A programme of capital grants, to support the deployment of pilot devices, where all significant Irish projects are supported, to ensure that at least one pilot plant is operational by the target date.
- A national programme of research and development comprising of two key elements
 - An *industry led R&D programme* to support the development of wave and tidal energy conversion systems
 - The development of *key centres/groups of niche expertise* to support emerging commercial interests (section 5.4)
- A targeted programme of *generic studies* to strengthen the research capacity and the body of knowledge in Ireland (section 5.5)

Benefits:

- Ireland develops an exporting knowledge and manufacturing industry around ocean energy technologies, which could bring new employment opportunities and tax revenues to the state.
- Ireland develops a body of research and niche technology expertise that will be relevant to other Renewable Energy sectors.

Risks:

- No technically or prospective economically feasible solution emerges from the work done in Ireland.
- Solutions do emerge, but a better solution is designed elsewhere and is supported internationally as the standard.

Resources required:

- Capital funding and Power Purchase Agreement for pilot plant development and deployment (3-5 devices)
- R&D Programme aimed at developing niche expertise in targeted areas (see 5.4) and supporting device development (i.e. Industry led R&D Programme)
- A commissioned programme of generic research studies (see 5.5). This programme of generic studies for wave should seek to capitalise on synergies with offshore wind R&D programme.

Indicative Funding Required

Capital Grants for Demonstration Projects - € 6 million
Price Supports for Demonstration Projects – 0.06 – 0.12 €/kWh
Research & Development Programme - € 5 million
Generic Research Studies - €1 million

Private sector funding will be required to match any public sector investment in device development and/or demonstration projects.

Unique Features of Option 1:

Deployment of Prototype Wave energy Converters.

A key element of this option for an Irish wave energy strategy should be to establish a carefully selected suite of prototype wave energy converters in the sea. This is the essential method by which technical and industrial interests can gain the knowledge, experience and momentum on which Ireland can develop a leading edge internationally exportable expertise.

A number of first generation shoreline and nearshore wave energy converter projects have been supported by the European Commission energy research programme. The Portuguese pilot plant at the Azores has been completed and is now under test and the LIMPET project on Islay, involving Wavegen and QUB, has been completed.

While the development of first generation converters could fulfil the requirement for generation of electricity utilising the wave energy resource, these devices must, of necessity, be manufactured close to the point of deployment. Therefore the potential for further industrial development with these converters will be confined to construction of the power plants in Ireland and the export of design expertise for construction abroad.

The focus of this strategic option is therefore on Ireland taking a lead in developing 'second-generation' floating wave energy converters as the central element of a research, development and demonstration programme. Second generation systems, usually Point Absorbers, have the advantage of being modular and of relatively small size (500 kW – 2MW). This facilitates their manufacture in Ireland for shipping to any deployment site, world-wide.

A clear strategy for the realisation of these converters must be developed and progressed to fulfill the objectives of this aspect of the programme.

The minimum that must be achieved for all converters is a theoretical understanding of the converter behaviour together with wave tank testing and an engineering design and assessment. This must be followed by the construction of a working prototype and its deployment at sea, along with an appropriate monitoring programme.

The successful implementation of this part of the proposed programme will result in working prototypes to allow further development towards commercial production. In terms of commercial performance the systems/converters must aim to close the gap, in terms of cost/kWh produced, with other renewable energy systems.

The simultaneous pursuit of an Offshore Wind Research, Development and Demonstration programme would potentially have major synergies with a Wave Programme. Specifically it would strengthen marketplace confidence in offshore deployment and the operational aspects of projects including installation and servicing, grid integration, transmission, energy storage etc. Within the timeframe of the proposed wave energy programme a successful Offshore Wind Demonstration Programme could in turn stimulate a more advantageous climate for the deployment of wave devices in tandem with appropriate price support mechanisms. Many of the generic R&D requirements identified in 5.5 would require similar investigation as part of a generic programme of R&D for Offshore wind.

5.2 Option 2

The risk involved in attempting to develop indigenous technology leadership and an export industry in ocean wave and tidal energy may be too great to justify the level of support identified in Option 1. A commitment to develop wave energy without a specific focus on developing an indigenous solution would provide Ireland with a means to utilize the abundant Irish resource and may result in the development of research excellence supporting an exportable technology industry. Such a programme would require that pilot plants be deployed in Irish waters by 2007; however they would not necessarily need to be Irish technology solutions.

Attracting pilot plant development to Ireland should be easy given the abundant resource available. However, many systems would hesitate to risk a pilot in the most aggressive environments, and other countries are offering power purchase price arrangements to attract developers to what may be less aggressive sites. To meet the goal of having a pilot plant deployed by 2007, Ireland would need to offer a Power Purchase Price attractive to developers. This could be in the region of 0.20€/kWh – 0.28€/kWh.

Option 2 - Strategic Intent:

To provide Ireland with the means to utilise the Irish wave resource and develop an exportable core of research excellence.

Target:

- To see the deployment of a wave energy device, offshore Ireland, by 2007.

Strategy:

- A programme offering specific price supports for ocean wave pilot plants, as Portugal has done, or the announcement of a competition for power purchase agreements for wave energy plants, as British Columbia, Canada has done.
- The development of *key centres/groups of niche expertise* to support emerging commercial interests (section 5.4)
- A targeted programme of *generic studies* to strengthen the research capacity and the body of knowledge in Ireland (section 5.5)

Benefits:

- Ireland could benefit from continued development of leading edge expertise in the field. Some domestic manufacturing industry could also develop to service markets in and around Ireland, although the potential is lower than that from Option 1.

Risks:

- Expenditure remains high. It is not certain that a solution that is capable of providing economically competitive energy will be developed in the timeframe targeted in Option 2 even outside of Ireland.

Resources Required:

- Establishment of 2 pilot plant power purchase agreements
- R&D Programme aimed at developing niche expertise in targeted areas (see 5.4) and supporting device development (i.e. Industry led R&D Programme)
- A commissioned programme of generic research studies (see 5.5).

Indicative Funding Required

Power Purchase Agreement – 0.20 €/kWh – 0.28 €/kWh

Research & Development Programme - € 5 million

Generic Research Studies - €1 million

Private sector funding will be required to match any public sector investment in device development.

5.3 Option 3

As Ireland has a significant potential renewable energy resource in energy crops and wind energy, which are much more advanced and can be converted to energy using proven technologies, it may be a lower risk option to concentrate resources on these technologies rather than ocean wave and tidal energy in the near term.

There are currently two support programmes in Ireland that have designated ocean energy research and development a funding priority. Sustainable Energy Ireland's RE R, D&D programme and the Marine Institute's industry RTDI programmes both make funding available to ocean energy research. However funding under this option is likely to be limited and neither programme would have a ring-fenced figure for ocean energy research.

Option 3 - Strategic Intent:

To maintain a watching brief in the field of wave and tidal energy

Target:

- In two to four years time to make an appraisal of ocean wave and tidal energy, including progress reports from work funded through the programmes discussed below.

Strategy:

- Make funding available for wave and tidal energy research under the existing programmes operated by the Marine Institute and Sustainable Energy Ireland.
- Participate in relevant international working groups, including EU and IEA Level.

Benefits:

- The continued involvement of Irish researchers in the field and the continued development of indigenous research expertise.
- Continued learning from wider international experience.
- Advances will be made in device development through funding provided for tank testing and scale prototype demonstration devices. Such work will provide better information to device developers and to government of the costs and likely success of devices in Ireland

Risks:

- Sums are unlikely to be sufficient to assist industry in developing ocean energy to the point of commercial exploitation.

Resources required:

- The estimated level of indicative funding that might reasonably be provided for ocean and tidal energy from the above programmes is € 2million.

Programme:

Research priorities for ocean energy identified by both agencies include:

- Generic research in the areas of grid connection and flexible electric cabling connections, sub-sea cabling methods, mooring studies and other work that would be of benefit to many ocean energy applications;
- Modelling of wave energy device performance and survivability both theoretically and in wave tanks;
- Resource studies for wave and tidal flow rates
- Demonstration device support

In addition, Ireland would continue to channel resources towards internationally co-operative research efforts such as the European Thematic Network on Wave Energy and the IEA Implementing Agreement on Ocean Energy Systems.

5.4 A National Wave Energy Research Programme to build up niche expertise in targeted areas

A targeted national programme of research and development for wave energy conversion converters is required to consolidate and exploit the research undertaken in Ireland to date. The main objective would be to support the development of strong core research groups that will be capable of providing services to emerging commercial groups, which will ultimately be responsible for the development of the industry.

Research centres or groups should be supported in the following niche areas:

Hydraulics

Two devices under development in Ireland (the McCabe Wave Pump and the Wavebob) use hydraulics to extract energy and control the device. Hydraulics is also extensively used in most of the promising devices, as they are simpler to implement than electrical equivalents. R&D toward cheap, reliable hydraulics for use in seawater would benefit many developers and help towards giving Irish industry a capability in this area.

Modelling

Modelling of wave energy devices both theoretically and in wave tanks is an essential step in their development. At University College Cork, Ireland has an active research centre with extensive capabilities in both these approaches. There is still a wide range of topics that need to be modelled so that economic and safe design can be achieved. Tank testing for second generation converters in extreme waves, and mathematical behaviour of the arrays of devices that will combine to form power stations, needs to be undertaken. The existence of such an ongoing programme would mean that any new converters being proposed could be given preliminary assessment. The continuity of expertise at this Centre is critical if consultancy and advice is to be available for new projects. This has been highlighted recently in the

technical support given to Hydam Technologies for the deployment of the McCabe Wave Pump and to Wavebob for the large-scale tank testing in Hanover.

Turbine Technology

The most common power conversion system for wave energy converters involves an air turbine. The efficiency of these turbines in oscillating flow is crucial to the economic operation of the devices. Further work needs to be carried out into the turbine design and also into the performance of new designs such as that proposed by Setoguchi.

Power Take-off and Electrical Interfacing

The electrical interfacing and control for wave energy converters also needs to be further investigated. The interaction with weak local grids and the power quality are both critical to the successful production of wave power. Converter modelling and electrical power conversion systems will need to be studied and refined in the research programme.

5.5 Generic Studies and Supporting Measures

There are a number of potential obstacles to deployment of wave energy schemes as evidenced by the experience of other renewable energy technologies under the AER schemes and EU Framework Programme for Research. These are not unique to wave energy and are being prioritised under the current Research, Development and Demonstration Programme of Sustainable Energy Ireland.

Electricity System Constraints

The west coast of Ireland and the rural areas are characterised by a weak grid and by electricity capacity constraints, because the electricity network structure has been designed for remote and distant big power plants and not for embedded small-scale generators. The cost to reinforce the grid will be high.

The Renewable Energy Strategy Group has recommended a short and medium term strategy to tackle a number of technical and financial issues associated with connecting wind farms to the network and upgrading the network to accommodate additional wind farms. The short-term strategy will be based on connection charges proportional to electricity demand of an area, while the medium term strategy proposes the upgrade of the national grid totally funded by the National Development Plan.

Grid Connection

A critical consideration in harnessing wave power is the connection to the electricity grid. While pilot projects can be connected to the 10/20kV systems, the deployment of early commercial phases of wave energy systems will require connection at least to the nearest 38 kV substation and longer term scale deployment will require

extension of the transmission system. An outline Figure showing the location of these is provided below.

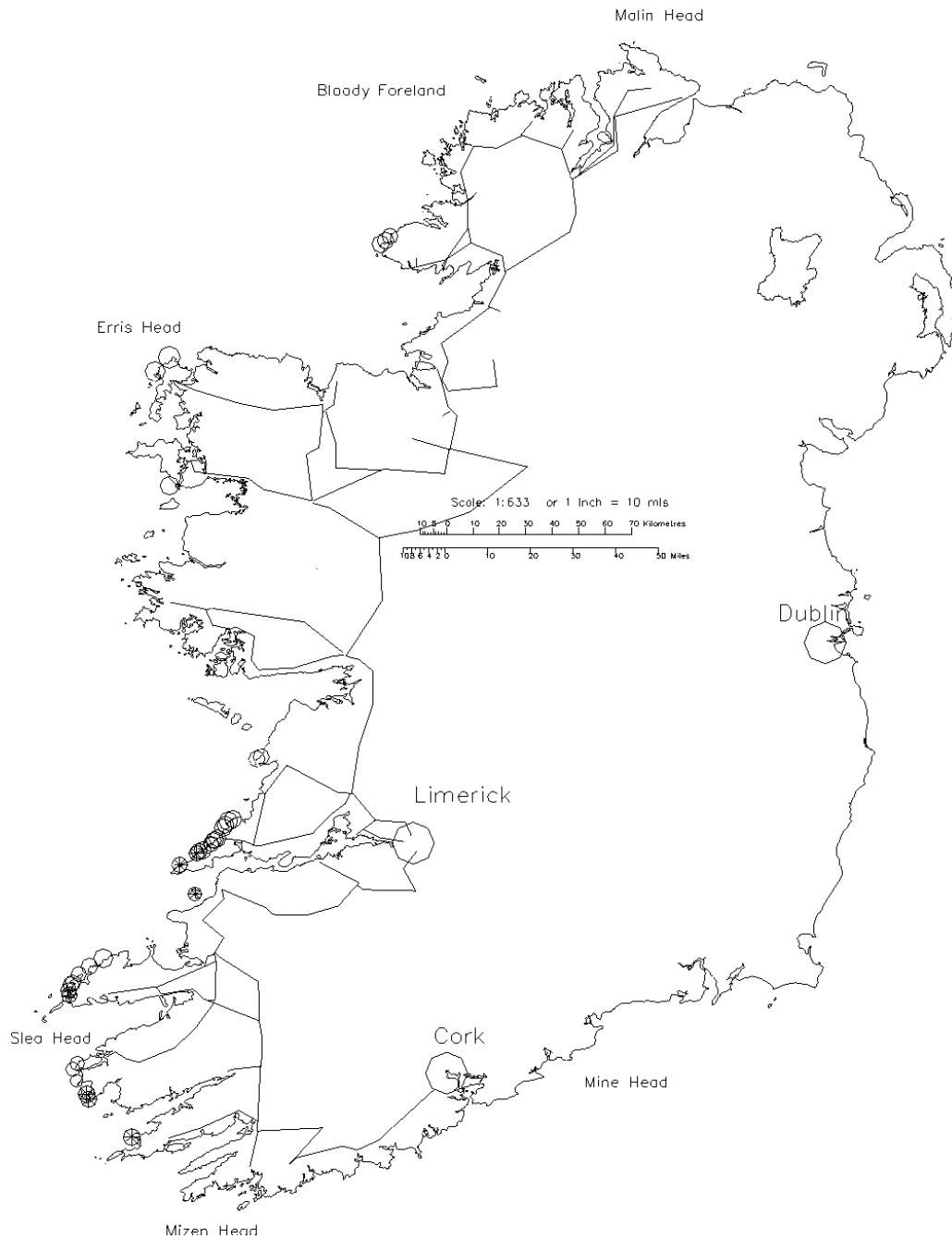

Source: A. Lewis

Fig 4. Approximate location of the 38 kV circuits near the west coast

ESBI (1996) has carried out a limited study within the EU ALTENER programme into the capacity of particular areas to accept variable electricity generating input. There is a need for further studies to be carried out on the interaction of these converters with the local grid as new methods for connection and interfacing are being developed. The CER has recently commissioned a study, which attempts to model

the grid in order to better estimate the capacity of intermittent generation that the current system can accept.

The connection between the wave energy converter and the grid will involve two stages.

- i. The subsea connection (not required for shoreline devices), which in some cases requires large flexible cables. The shorter this connection the lower the development cost will be and so sites with deep water close to the shore are to be preferred. At this stage it is difficult to estimate the cost of the subsea connection, as this will depend upon the size of the installation. Smaller installations will be very expensive because the basic plant mobilisation costs for the subsea cable laying are very high. Cables have recently been laid from the shore to several West Coast islands but the costs of these are not available.
- ii. The landline connection cost can be based upon quoted values from the ESB under the recent AER III competition, where connection to the local grid was ruled out and lines had to be constructed back to the nearest 38 kV substation. A typical 10 kV connection was quoted at about €24,000 per kilometre and a typical 20 kV line at €11,000 per kilometre, excluding substation and metering costs. The distance from the 38 kV substation will therefore be a major factor in the viability of a particular installation but will be proportionately less important as the installation size increases. In the first instance however, it will be a major factor influencing the costs and siting of pilot plants unless studies show that connections can be made into the existing power lines.

Site Selection

A study that identifies the best areas for wave energy devices would promote the interest of device developers in Ireland. Topics to be studied would include:

- Wave power levels and variability
- Sea bed conditions
- Grid connection points and grid strength
- Environmental acceptability

In selecting sites for short-term development an upper limit maximum wave energy level, over a 12-hour period, of 750 MW/km has been suggested, in view of the lower extreme forces and increased chances of converter survival. Further research is urgently needed in the area of wave forces, as the economics of wave energy converters depend upon the costs of the structure. A better understanding of the wave forces in this situation would also be of interest to designers of all coastal structures.

The Marine Institute has deployed three metocean buoys around the coast. Two of these are off the West Coast and initial outputs from these show that there is a good potential data data-set building up for detailed analysis. Correlations with Met Office prediction models can be undertaken which will increase confidence in the design and operation of wave energy devices.

Energy storage

New or cheaper methods of energy storage would be useful to most wave energy technologies and facilitate better integration with the grid. This is a medium to long-term issue and is relevant to all intermittent energy resources, although it is not expected to be a critical constraint until grid penetration by these sources reaches 15-20%.

Sub-sea cabling

Cheaper sub-sea cabling and installation methods would promote not just wave energy but Ireland's potential offshore wind and tidal stream resources.

Planning Permission

There will be a range of issues associated with the deployment of wave energy devices in large arrays that will need to be addressed in terms of planning. New guidelines for local authorities and local involvement, together with public environmental concern will be required.

Operation and maintenance strategies

These are often the least developed aspects of wave energy schemes and they represent a relatively inexpensive area of study, suitable for universities or consultants. They are very device-specific and should be undertaken in association with specific developments.

Weather and Wave Forecasting²

Wave forecasting is important to both the operation and the maintenance of offshore systems. Very often access to the installation is restricted by the weather. Access is often not possible in high winds or if using boats in high seas. Forecasting good weather windows is therefore useful to planning maintenance operations.

Several meteorological and other organisations offer wind and wave prediction services over forecast horizons of a few hours to a few days.

Shorts time-scale wave forecasting may be of use to wave energy device developers. This helps adjust control systems to the mean sea levels. Some systems can benefit from fast (seconds to minutes) predications to optimise their control strategies. R&D into fast wave climate predictions may be of benefit. This will depend on the concept, its control system and the value of the power that it produces.

Forecast horizons of the order of minutes to hours can be helpful in protecting devices from extreme loads caused by storms. Devices can be, for example, de-tuned, reefed, furled or sunk to wait out the storm. Good forecasting opens up the opportunities for lowering the engineering demands on extreme loading, particularly where the number of high stress cycles can be reduced as a result.

² Boud, R.2002. Wave and Marine Current Energy; Status and R&D Priorities – A Report for the IEA

Forecast techniques appropriate to the development of ocean energy systems could be developed to help reduce the risks and uncertainties in operating the devices.

Forecasting also offers opportunities for maximising the commercial value of the wave energy. Without forecasting, the energy produced by the device would vary without warning, causing difficulties for the electrical grid operators and leading to additional costs. If the output could be predicted, then the net value of the electricity is higher. In some electricity markets, such as in the UK, this variability is penalised through higher charges or lower prices. Good forecasting over periods of 30 minutes to days is therefore valuable.

Mooring³

Many of the proposed concepts will have similar mooring or foundation requirements. There would be some benefit to many developers of a generic mooring study looking at appropriate options for different types of wave energy devices. These types would comprise the following attributes

- Slack-moored floating devices or bottom-mounted devices
- With or without the ability to allow the device to adjust its attitude to the prevailing wave direction
- Means of operation – pitch, surge, surface following, etc.
- Different sea bed conditions – rock, sand, etc.

Previously, specific suggestions for research in this area have included the use of lighter synthetic ropes, quick-release couplings, taut moorings, on the long-term fatigue characteristics of mooring options, fretting resistance and the reliability of compliant couplings. Many of these issues could be addressed through a literature review or on a device-by-device basis with help from existing mooring equipment suppliers.

5.6 Development of a field test facility

One additional option, which may merit consideration, is the development of a field test facility, which could be used by both Irish and international device developers.. It is recognised that the specific configuration of a test facility will require detailed consideration. Each device will have site-specific characteristics and it may be difficult to provide a site where conditions will be appropriate for every device. However, the benefits of a serviced and monitored site may be an important factor in the process of deploying and testing devices. The potential for developing a common data-monitoring procedure could also be a significant factor.

A similar facility has been proposed for the West coast of Scotland at a cost of €12m - €16m. In addition it may be possible to use such a platform for other complementary

³ Boud, R.2002. Wave and Marine Current Energy; Status and R&D Priorities – A Report for the IEA

uses such as the collection of time series data for environmental monitoring thereby enhancing the rationale for establishing such a costly infrastructure.

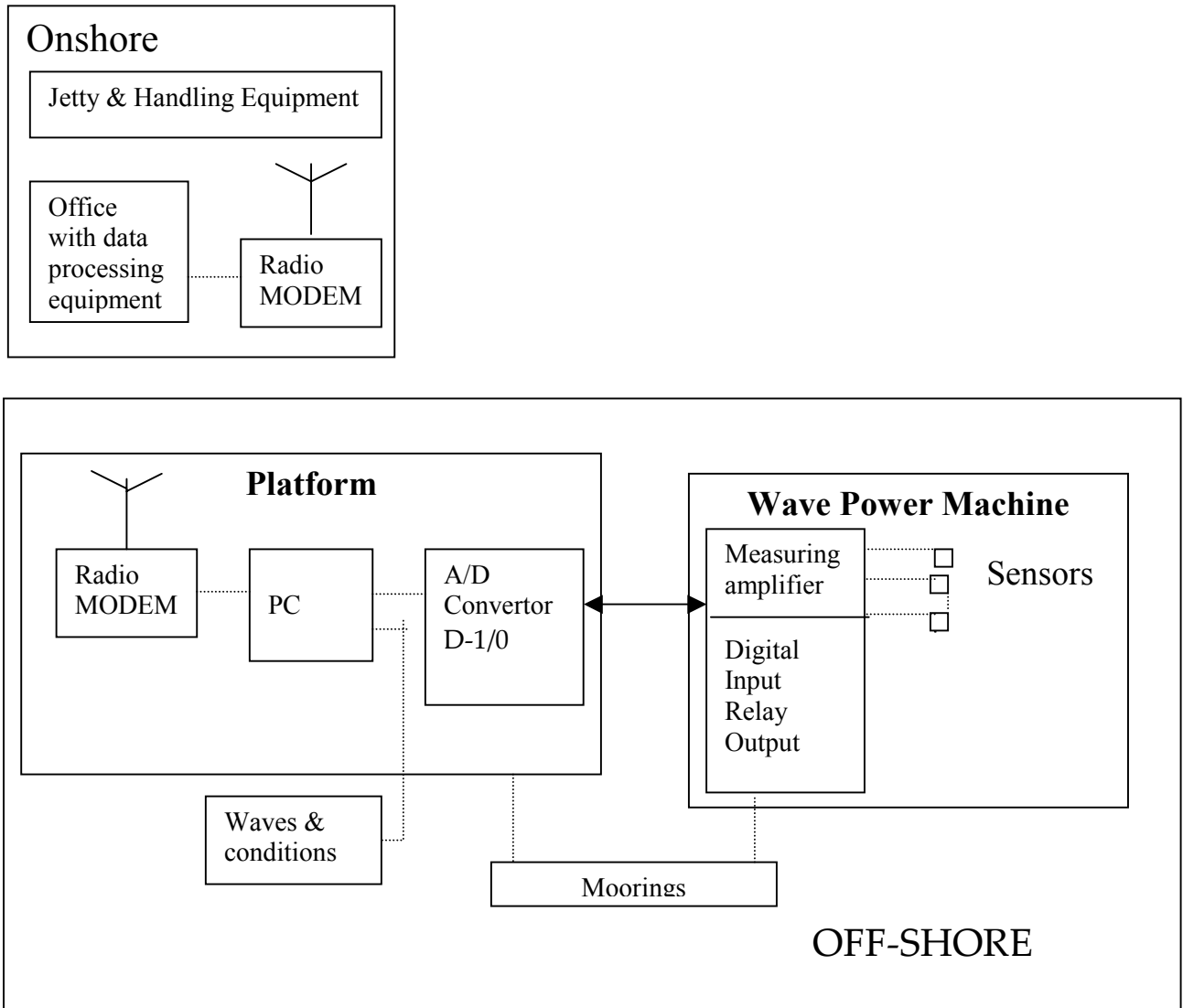

APPENDIX 1.

WAVE ENERGY CONVERSION TECHNOLOGIES

1. Device Developments

There are over 1,500 patents on wave energy devices. This overview will concentrate on those which have been deployed or which are scheduled to be deployed over the next three years and which look economically promising.

1.1. Shoreline Devices

Shoreline devices are fixed to or embedded in the shoreline itself. This has the advantage of easier maintenance and/or installation as well as avoiding the need for deep-water moorings or long lengths of underwater electrical cable. However, such devices experience a much less powerful wave regime because of loss of wave energy as the waves travel towards the shoreline. This can be partially compensated by siting the devices at locations of natural energy concentration (“hot spots”). However, the deployment of such schemes is limited by requirements for shoreline geology, tidal range, preservation of coastal scenery etc.

The main type of shoreline device is the oscillating water column (OWC), which is shown schematically in Figure 1. It consists of a partially submerged, hollow structure, which is open to the sea below the water line thereby enclosing a column of air on top of a column of water. As waves impinge upon the device they cause the water column to rise and fall, which alternatively compresses and depressurises the air column. If this trapped air is allowed to flow to and from the atmosphere via a turbine, energy can be extracted from the system and used to generate electricity. Because of the oscillation in air flow, OWCs normally use Wells turbines to power the electricity generators. These have the property of turning in the same direction regardless of which way the air is flowing.

Wavegen’s LIMPET

This is a 500 kW OWC mounted on the cliffs of the island of Islay in Scotland (Wavegen, 2001). It was developed by Wavegen (Inverness) in conjunction with the Queen’s University, Belfast. They used a novel construction method in an attempt to reduce construction costs and ease installation, i.e. the chamber for the device was hollowed out of the shoreline, leaving a rock bund to keep out the sea and the bund was removed when the device had been installed (Fig 2). This device started to generate electricity in November 2000 and has continued to operate successfully since then (Fig 3). However, the device has to dump a lot of its output because of limitations on the weak local grid, illustrating the importance of having a good grid connection point. In addition, *in situ* construction, even with the rock bund, proved time consuming, difficult and expensive.

Funding for the development and deployment of the device came mainly from industry and private investors, although some funds were provided by the European Commission.

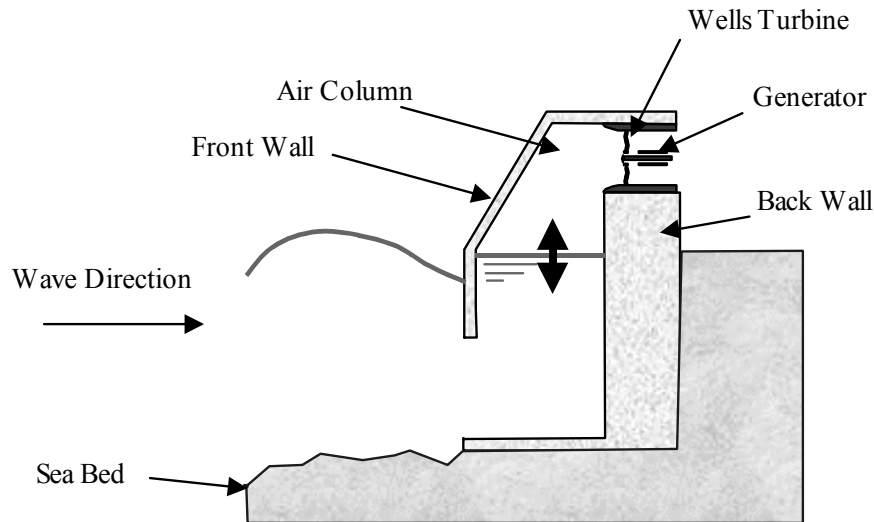

Fig 1: Outline of an OWC

The European Pilot Plant

The European Pilot Plant on the Pico Island in the Azores is an OWC, developed by the Instituto Superior Técnico (IST) of Lisbon, Portugal (Figure 4). This 400 kW plant was designed as a testing facility at full scale, but it is also used to supply, on a permanent basis, a sizeable part of the island's energy demand (Falcão, 2000). To date, the plant has met with several problems and its current status is unclear.

It is difficult to be definitive about the project but the general observation is that various lessons can be drawn for future projects:

- Choose a site carefully – not just for its available wave energy. Access to the site is difficult and not possible at seas greater than 2.5 m high (Falcão, 2000).
- Avoid remote locations until the technology is proven. Experts had to travel from Portugal, Ireland and the UK whenever problems arose, adding greatly to costs and delays.
- Ensure adequate infrastructure. The island has one engineering company which could undertake this size of project. Hence, this project did not benefit from competitive tendering and any problems had to await an opening in the company's schedule before they could be dealt with.
- Include good project management. The leading participants were all academic/Government institutes, whose forte was not project management. This was compounded by travelling distances involved.
- The importance of industrial funding, with the discipline that private industry involvement brings.

1 Virgin Site

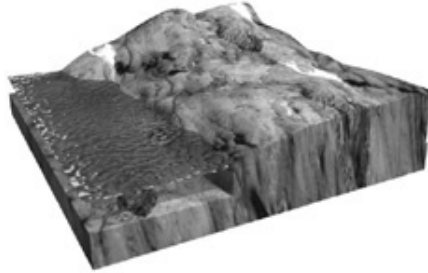

2 Rock Excavation

Natural Rock Cofferdam

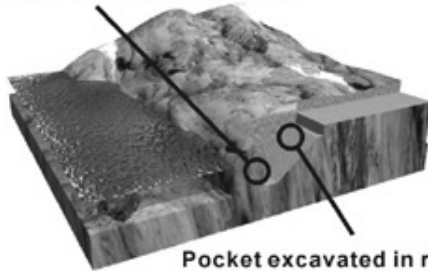

Pocket excavated in rock for device construction

3 Device Construction

Combined precast / insitu concrete construction

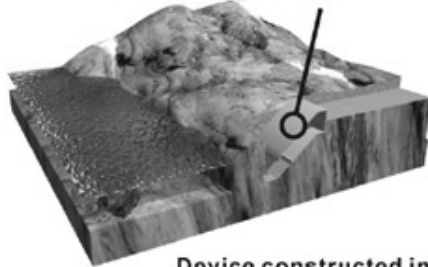

Device constructed in dry conditions

4 Completed Device

Device operational

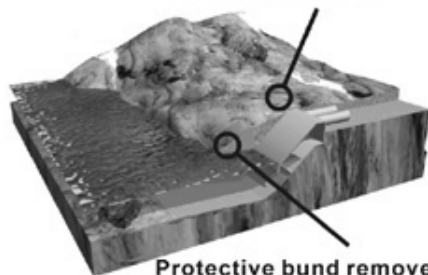

Protective bund removed

Drawing supplied by Wavegen

Fig 2: Construction Sequence for the LIMPET



Picture supplied by Wavegen
 Fig 3: The LIMPET on Islay

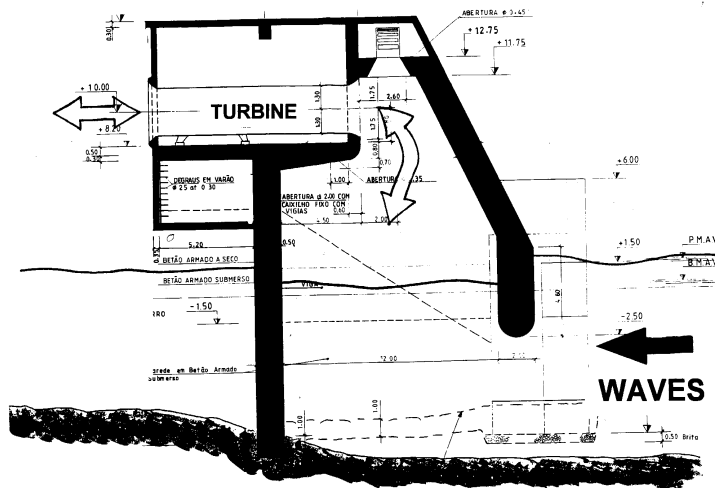

Illustration supplied by IST, Portugal.
 Fig 4: Outline of the European Pilot Plant

The Energetech OWC

This is an OWC being developed by Energetech in Australia (Energetech, 2001). It represents the next stage in development of the OWC.

- It uses a novel, variable pitch turbine instead of the Wells to increase the systems efficiency (probably by as much as 30-40%).
- It has a relatively cheap parabolic wall behind the OWC to focus the wave energy on to the more expensive collector and associated M&E plant (Fig 5). The parabolic wall adds about 30% to the overall scheme costs but it will boost the output of the scheme fourfold.

This scheme has already a power purchase agreement with the local utility at Port Kembla (80 km south of Sydney) for a 500 kW plant. The plant is scheduled to start operating in the second quarter of 2002. This technology (together with the Pelamis – see later) has also won a recent competition run by BC Hydro to supply an initial 4 MW of electricity to Vancouver Island in Canada. Discussions are underway to supply this technology in other countries but commercial confidentiality does not allow these to be detailed.

Nearly all the funding for the development and deployment of this technology has come from commercial sources. Some impetus for this funding was generated by the granting of a power purchase agreement.

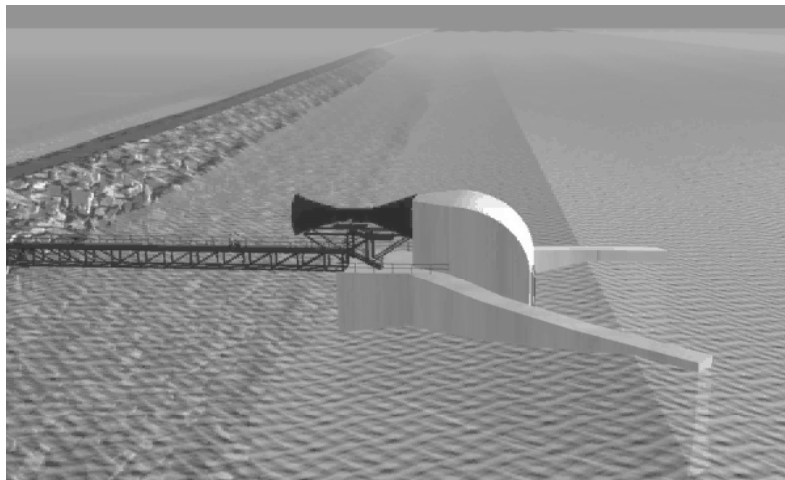

Drawing supplied by Energetech

Fig 5 Artist's Impression of the Energetech OWC

The Pendulor

This is a surging type of wave energy device developed by the Japan Marine Science & Technology Centre (JAMSTEC) of the Ministry of Education, Culture, Sports, Science and Technology in Japan. It consists of a rectangular box, which is open to the sea at one end (Fig 6). A pendulum flap is hinged over this opening, so that the actions of the waves cause it to swing back and forth. This motion is then used to power a hydraulic pump and generator. Several schemes of 5kW or more have been built in Japan. This has proven to be one of the most successful schemes in Japan and there are plans to develop a larger plant.

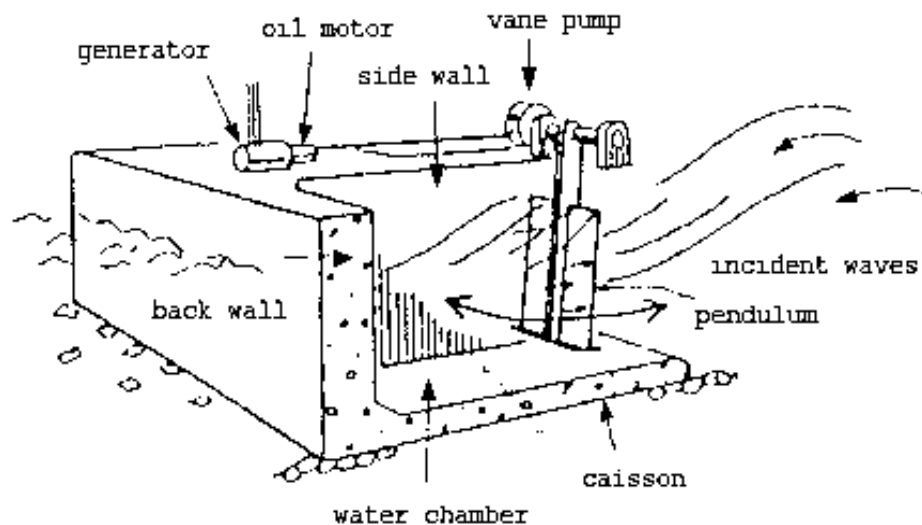

Drawing supplied by JAMSTEC

Fig 6: The Pendulor

The TAPCHAN

This is a shoreline WEC of the overtopping type developed by Norwave AS (Fig 7). It consists of a gradually narrowing channel with wall height equal to the filling level of the reservoir (typical heights 3-7m). The waves are amplified in a narrowing collector until the wave-crests spill over the walls into the reservoir. The water in the reservoir is allowed to return to the sea via a low-head turbine and generator. A demonstration device was built in 1985 at Toftesfallen, Norway but was seriously damaged in 1991. The combination of low tidal range and naturally occurring reservoir limits the replication potential of this device.

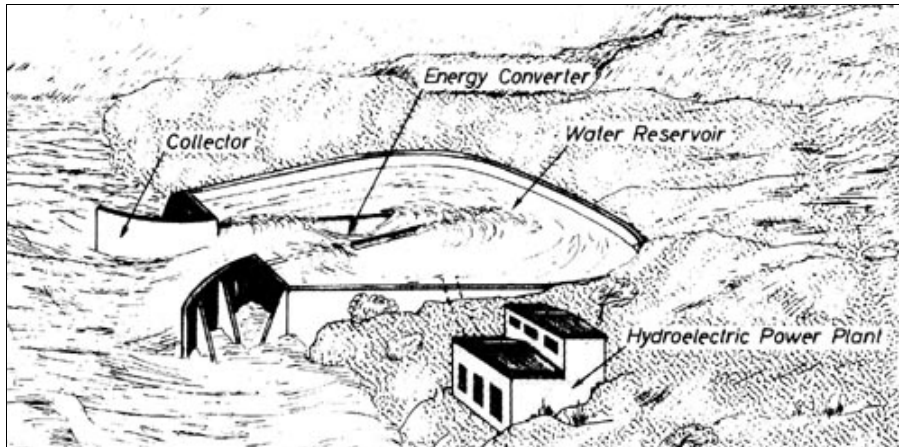

Fig 7: Outline of the Tapchan

1.2. Near Shore Devices

The OSPREY

The main prototype device for moderate water depths (i.e. < 20 m) is the OSPREY, developed by Wavegen in Inverness (Fig 8). This is a 2 MW, bottom standing OWC, with provision for inclusion of a 1.5 MW wind turbine (Wavegen, 2001). Since there could be environmental objections in some regions concerning large farms of wind or wave energy devices close to the shore, this system aims to maximise the amount of energy produced from a given amount of near shore area. A prototype device with a steel body failed during problems in installation in 1996, so a new concrete-based design has been developed for deployment in the near future. Again, a considerable amount of work has been done on this device, which is coming to the end of its R&D phase and is ready for commercial demonstration. This device was the winner of the AER III competition for wave energy in the late 1990's. This device was developed and deployed with only commercial sources of funding.

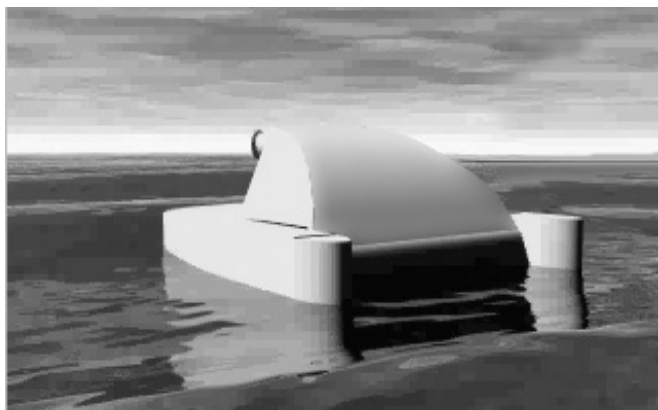
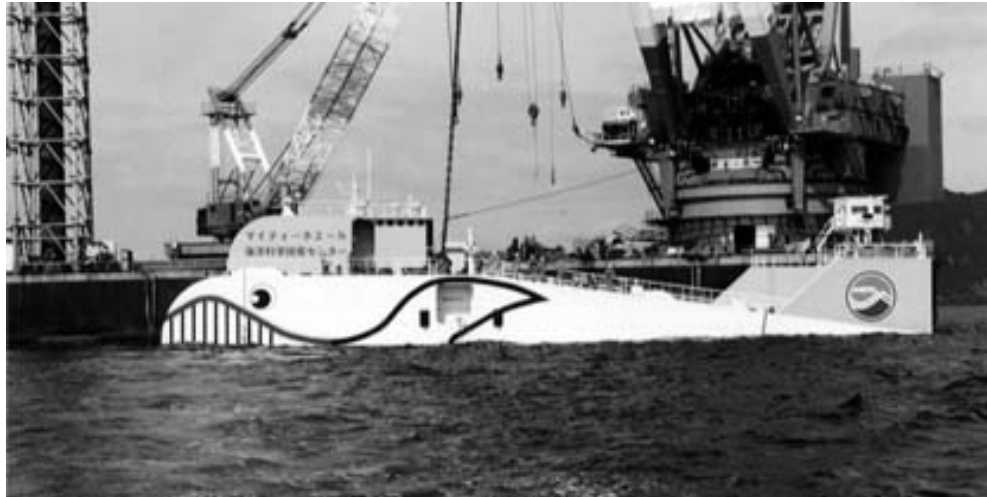

Fig 8 Artist's Impression of the OSPREY

The Mighty Whale

The Mighty Whale is a floating OWC based device for offshore operation, developed by JAMSTEC. A 120 kW prototype with 3 OWC's in row has been operating since 1998 in water depths of 40 m, 1.5 km off Nansei Town in Japan (JAMSTEC, 2001). However, the device has proved to have a low overall efficiency.



Photograph courtesy of JAMSTEC

Fig 9 The Mighty Whale Being Launched

1.3. Offshore Devices

This class of device exploits the more powerful wave regimes available in deeper water (> 40 m depth). In order to extract the maximum amount of energy from the waves, the devices need to be at or near the surface (i.e. floating) and so they usually require flexible moorings and electrical transmission cables.

There are many different types of offshore device, each with its own pros and cons. Early designs were for multi-megawatt schemes but the recent trend has been towards smaller devices in the tens to hundreds of kilowatts range, which could be deployed in arrays to give a greater output.

The McCabe Wave Pump

This indigenous wave energy device, currently under construction by Hydam Ltd., consists of three narrow rectangular steel pontoons, which are hinged together across their beam pointing into the incoming waves. The fore and aft pontoons move in relation to the central pontoon by pitching about the hinges and energy is extracted from this rotation by linear hydraulic rams mounted between the central and two outer pontoons near the hinges. This energy can be used in two ways, either to provide electricity by driving an hydraulic motor attached to a 400 kW generator or to produce potable water by supplying pressurised sea water to a reverse osmosis plant. A 40 m long prototype of this device was deployed off the coast of Kilbaha in Ireland and a commercial demonstration scheme has been constructed and is awaiting further funding before deployment.

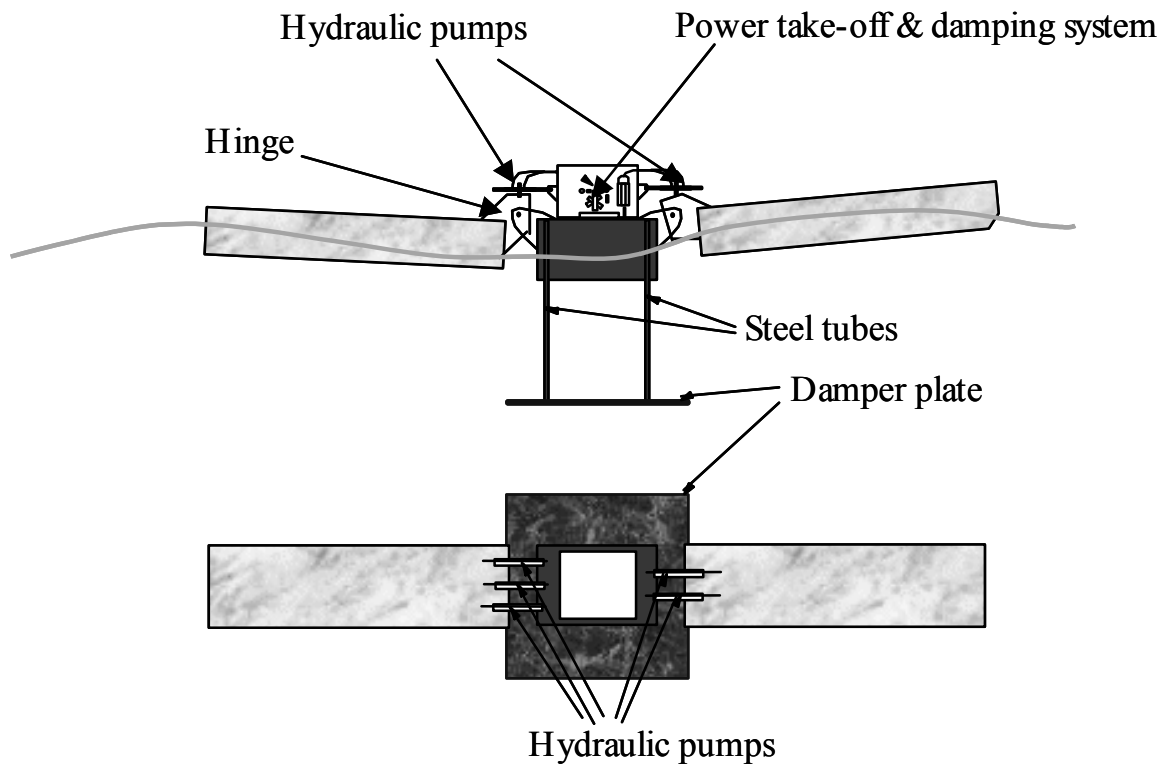

Fig 10 Outline of the McCabe Wave Pump

The OPT WEC

The Wave Energy Converter developed by Ocean Power Technology (OPT WEC) in the USA consists of a simple and ingenious system to drive the generators using mechanical force developed by the wave energy converter. It has very efficient power conversion electronics to optimise the generated electricity, which are housed in a watertight compartment within marine proven ocean-going buoys. The OPT system has been tested at a large scale in the Eastern Atlantic and the first commercial schemes are about to be built in Australia and in the Pacific, with a number of other schemes in the pipeline. Commercial sensitivity prevents disclosure of more information.

The Archimedes Wave Swing

This device is being developed in the Netherlands by Teamwork Technology with the support of several large engineering companies and Nuon, a leading Dutch electrical utility (Waveswing, 2001). It consists of a cylindrical, air filled chamber (the "Floater"), which can move vertically with respect to the cylindrical "Basement", which is fixed to the sea bed (Fig 11). The air within the 10m – 20m diameter "Floater" ensures buoyancy. However, a wave passing over the top of the device, alternatively pressurises and depressurises the air within the Floater, changing this buoyancy. This causes the Floater to move up and down with respect to the Basement and this relative motion is used to produce energy. The design for a 2 MW

Pilot scheme is to be deployed near Portugal in October 2001 (Fig 12). This device has been built using mainly commercial and industry funds, with Nuon being a major shareholder in AWS.

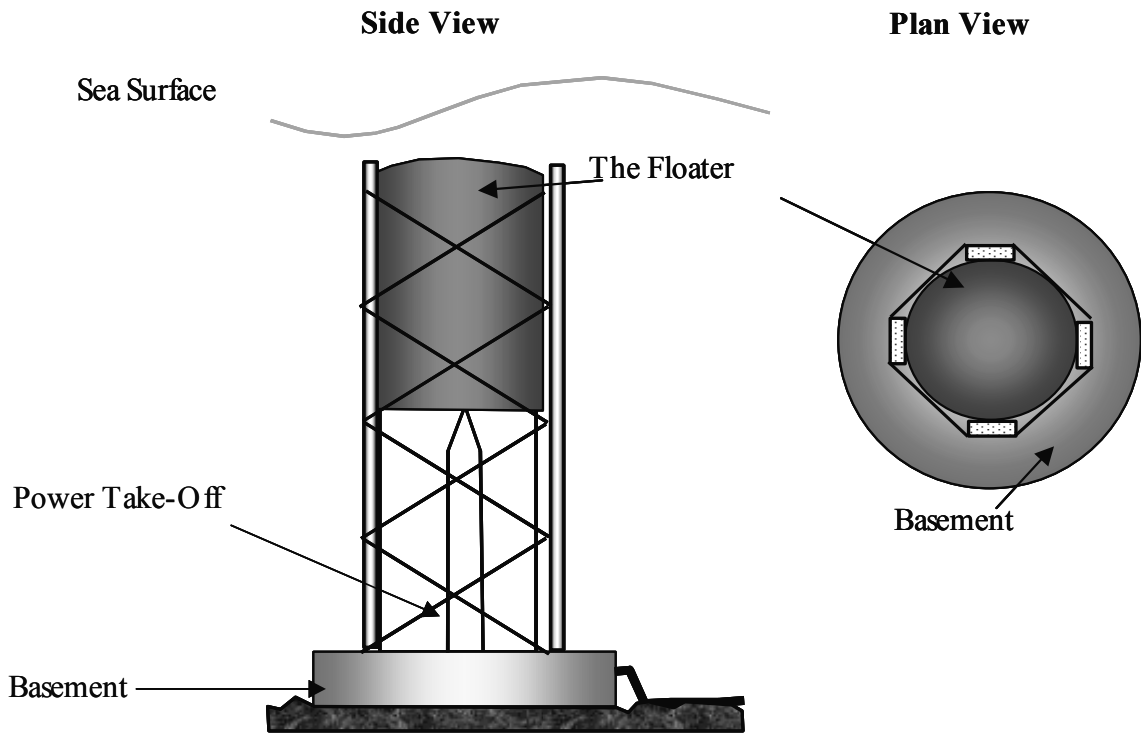

Fig 11 Outline of the Archimedes Wave Swing



Photograph courtesy of AWS

Fig 12 The Archimedes Wave Swing about to be Launched

The Pelamis

The Pelamis device is being developed by a small engineering company, Ocean Power Delivery in Edinburgh. It has a semi-submerged, articulated structure composed of cylindrical sections linked by hinged joints (Fig 13). The device points into the incoming waves, thereby reducing the overall loading on the structure. As the waves travel down the length of the device, they cause the cylindrical sections to move relative to each other. This wave induced motion is resisted by hydraulic rams in these joints between the sections, which pump high pressure oil through hydraulic motors via smoothing accumulators. The hydraulic motors drive electrical generators to produce electricity.

A device is being developed for the Scottish Renewables Order, which is rated at 375kW and is 130 m long and 3.5 m in diameter. It has been tested at 1/7th scale and there are plans for deployment of the full size device in 2002, following an extensive testing programme.

This technology (together with the Energetech OWC) has also won a recent competition run by BC Hydro to supply an initial 4 MW of electricity to Vancouver Island in Canada.

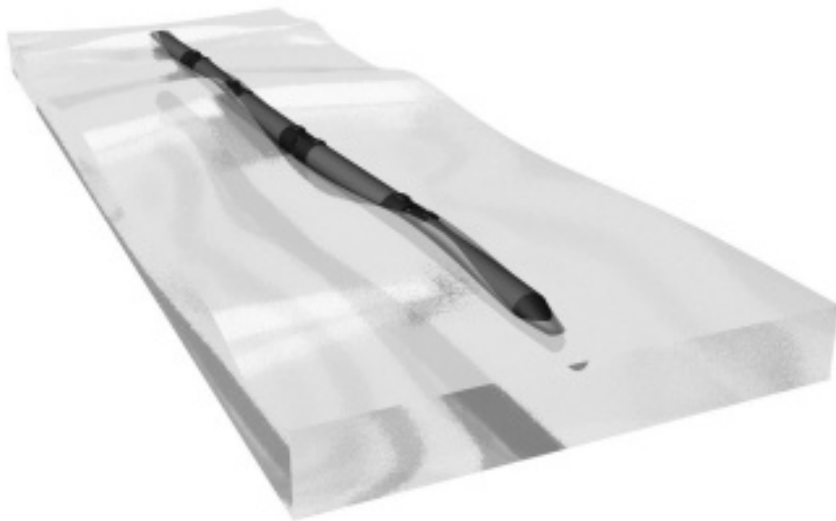

Fig 13 Artist's Impression of the Pelamis

Floating Contour Converter

Air chambers within which the pressure varies either by direct contact with the water surface or indirect contact through a membrane.

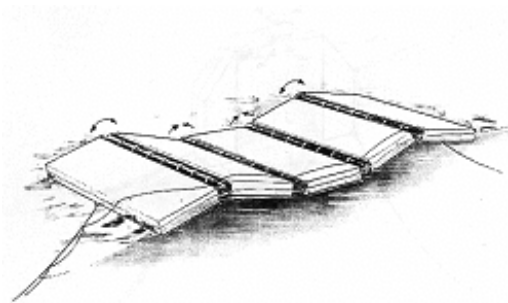

Fig 14 Floating Contour Converter

2. Status and Applicability to Ireland

All the devices above have either been demonstrated or are nearing deployment of their first prototype. There are numerous concepts under development around the world but these require significant R&D to bring to fruition and some are doomed to failure.

All of the above devices apart from the Tapchan are suitable for deployment in Irish waters. The Thorpe report of November 2001, "Options for Wave Energy in Ireland", commissioned by SEI, indicates potential electricity prices levels of €0.06-0.12 per kWh for early deployment and €0.05-0.08 per kWh for later deployment. From the current position of the technology, these would represent a challenging target.

APPENDIX 2.

SUMMARY OF INTERNATIONAL DEVELOPMENTS IN WAVE ENERGY

1. Denmark

Resource

The annual wave energy resource of Denmark has been estimated to be about 30 TWh with a low annual wave power regime of 7-24 kW/m. A Danish Wave Energy Atlas will be soon finalised and published.

Funding

The Danish Wave Energy Programme started in 1996 spending € 5,300,000 between 1998 and 2002 in an attempt to emulate Denmark's previous success with wind energy. Several Danish organisations also receive funding from the European Commission.

Activities

A Danish Wave Energy Association was formed in 1997 to disseminate information and arrange meetings for its members and those interested in wave energy. The Danish Energy Agency has established an Advisory Panel of experts to advise on appropriate wave energy testing and research:

- The Danish Hydraulic Institute – DHI
- The Danish Maritime Institute-DMI
- The Folkecenter for Renewable Energy
- The University of Aalborg
- The Technical University of Denmark
- The Danish Wave Energy Association.

In the first two years, 40 new ideas were developed into models and tested in wave tanks either in DMI or DHI using guidelines prepared by the Advisory Panel (Nielsen and Meyer, 1998). Two pilot projects, the Point Absorber and the Wave Dragon, have been tested at an outdoor site in Nissum Bredning. A proposal for hybrid wave and offshore wind pilot project in Horns Rev is under consideration.

In addition to generating data on the performance of the schemes (both capture efficiency and power conversion), the Danish Programme has developed a methodology for comparing the economic prospects of the different systems (not an absolute economic evaluation).

The Danish Wave Energy Programme is promoting public information and education by producing film and information folders.

Further details can be found in the status report on the programme (BS, 2000).

Denmark is a founder member of IEA Implementing Agreement on Ocean Energy Systems, signed in October 2001.

2. France

Resource

France has annual power levels of 30-50 kW/m on its Atlantic seaboard and 4-5 kW/m on the Mediterranean side.

Funding

A number of wave energy projects were operated in France during the early part of the last century but the sources of funding are unclear. The few recent activities were funded by the Government and the European Commission through universities.

Activities

A number of projects were carried out in the 1980's by the Centre Nationale pour l'Exploitation de Oceans (CNEXO) but funding was stopped after the initial development phase.

The Ecole Nationale Supérieure de Mécanique (ENSM) Nantes has been following a programme of fundamental research, which, since 1995, has focussed on the development of wave absorbing devices (paddles) for the equipment of wave basins. The same research group is participating to the development of the European wave power pilot plant on Pico island (Azores), mainly involved on (sub)-optimal control strategies for wave energy OWC devices.

3. Norway

Resource

Norway has a large potential wave energy resources (400 TWh/year) with wave power levels between 50 kW/m in the north and 23 kW/m in the south (where it is shielded by Scotland).

Funding

Funding for wave energy has come primarily from the Government through the Norwegian Research Council and Norwegian Universities. The main exception to this has been Government collaboration with two Norwegian companies (Kvaener Brug A/S and Norwave A/S) and the Centre for Industrial Research, leading to the deployment of two prototype devices.

Activities

Research in Norway began in 1973 at the Department of Physics in the Norwegian University of Science and Technology – NTNU, with governmental support from 1978. In the 1980's, two shoreline wave converters were deployed at Toftestallen about 35 km north-west of Bergen:

- The 500 kW Multi-Resonant Oscillating OWC, built by Kvaener Brug in 1985. This plant operated successfully but was damaged in severe storms in 1988, when it ceased to function.
- The 350 kW Tapered Channel built by Norwave A/S. This plant operated successfully for several years but was damaged during operations to improve its performance in 1991, when it ceased to function. In 1996, Norwave A.S planned to export the Tapchan technology to Java in Indonesia, but due to various problems within the country (economic and civil unrest), the project still awaits commissioning. Interest has recently been shown in reopening the Tapchan in Toftestallen

The Norwegian Research Council also sponsored R&D on the Controlled Wave Energy Converter – ConWec. Since 1994, work on the ConWec has been carried out between the company Brodrene Langset AS and the Department of Physics of the Norwegian University of Science and Technology in Trondheim - NTNU (Lillebekken, Aakenes and Falnes, 1998).

Oceanor A.S., a oceanographic Norwegian company, together with the National Technical University of Athens and the Italian ISDGM (Istituto Studio Dinamica Grandi Masse) have developed EUROWAVES, a new European wave energy atlas software package, which is part of the 4th EU Framework Programme (Oceanor, 2000).

4. Portugal

Resource

Portugal has favourable wave power levels of 30-40 kW/m, with the highest being to the North. The overall resource has been estimated at 10 MW, of which half could be exploited (Mollison and Pontes, 1992).

Funding

The Portuguese Ministry of Science and Technology provides funding for R&D and Demonstration (led by companies) projects through different programmes but most Government funding is provided by the Ministry of Economy using national funding in addition to money from the European Commission.

Activities

In Portugal, wave energy research started in 1978 at IST in Lisbon and later it was joined in 1983 by the Instituto Nacional de Engenharia e Tecnologia Industrial (INETI). Their main area of interest has been oscillating water columns.

Since 1986, Portugal has been involved in the planning and construction of a shoreline Oscillating Water Column on the island of Pico in the Azores. This project was carried out in association with an international group, including:

- IST
- INETI
- University College Cork (model testing)
- Queen's University of Belfast (electrical aspects)

- Edinburgh University (manufacture of variable pitch turbine)
- Wavegen (manufacture of conventional turbine)
- Empresa de Electricidade dos Açores RP – the local electrical utility

The OWC in Pico was sponsored to promote wave energy research and development and provide the island with electricity, by being connected to the grid. The construction of the OWC was completed in the summer of 1998. However, after its completion, different interruptions and a flood in the electronic equipment room occurred.

Besides the development of the EU pilot projects, Portugal has been actively involved in the research and survey of wave energy resources in the country and in Europe. In 1997, INETI and a pan-European team developed and published the first European Wave Energy Atlas WERAAtlas, which covers an extensive area from the Mediterranean to the Baltic Sea. Again, this undertaking lacked authoritative project management: much of the effort was spent on numerous areas throughout the Mediterranean – areas where it was obvious from the start that the available wave energy resource would be too low to achieve economic wave energy.

The north coast of Portugal (Viana do Castelo) is the location chosen by Teamwork Technology BV - AWS (a Dutch wave energy company) for the development of the offshore wave energy converter, the Archimedes Wave Swing (AWS, 2001). The first prototype of

2 MW is currently being installed (10th November 2001). Portugal was chosen because of its good wave climate, adequate water depths close to shore and technical expertise in wave energy, features which it shares with Ireland.

5. UK

Resource

The UK is favourably situated with high offshore wave power levels (typically 60-70 kW/m). The overall resource has been estimated at 120 GW (Thorpe, 1992).

Funding

The original funding for wave energy within the UK was almost totally from Government. The immense wave power resource around the UK led to the original Wave Energy Programme (1974-1983) focussing on exploiting the maximum amount of resource possible, which led to a target design of 2,000 MW for the first wave energy schemes (sic). Colossal schemes were required to achieve this target, which would have entailed large construction costs, prolonged construction times and significant technical challenges. These factors led to high predicted generating costs and large capital costs for the first prototype designs (the Edinburgh Duck, Bristol Cylinder, NEL OWC, SEA Clam and Vickers OWC), which made all the technologies commercially unattractive. Hence, the Wave Energy Programme was significantly run down.

This correct decision has resulted in wave energy having a credibility problem, e.g. "If the UK could not make this technology work with their good wave power levels, engineering skills and leading academic institutions – who can?"

Work did continue at a much lower level of funding by the Government on small scale schemes, especially the shoreline OWC which was deployed on Islay in the early 1990's.

Work on wave energy began anew in the mid 1990's, led primarily by two SMEs: Wavegen and Ocean Power Delivery. Until recently, these companies obtained all its funds from commercial or private sources (Ocean Power Delivery did win some small grants). More recently both companies have received substantial funding from Government grants, with Wavegen recently being awarded over £1,500,000 to help build and deploy its "Project X". This resulted from the Government's decision in 1999 to re-open its wave energy programme, when its announced plans to spend in the region of £ 1,000,000 per annum on wave energy.

Scotland has provided a tranche of its renewables obligation for wave energy schemes (the third Scottish Renewables Order - SRO3), whereby developers would be paid a premium price for electricity delivered to the grid. This produced three successful applicants: Wavegen's LIMPET, Ocean Power Delivery's Pelamis and Seapower International's Floating Wave Power Vessel. Of these, only the LIMPET has yet been deployed.

Government funding through the Department of Trade and Industry is concentrated on industry-led projects. University-led projects are funded by the Engineering and Science research Council.

There is also considerable activity on a non-technical front:

- A report from the UK Marine Technology Foresight Panel (OST, 1999) was supportive of the development of wave energy in the UK. This panel was composed of experts from a variety of industries connected with marine activities (especially the offshore oil and gas industry) and consulted widely before reaching its conclusions.
- A Scottish Commission has been formed to promote the development of a wave energy industry in Scotland. This comprises representatives from the Scottish Parliament, NGOs, relevant industries, finance, etc. This has led to plans to develop an marine energy test facility in the Orkneys, which will provide the basic infrastructure for a device developer to attach to (including sub-sea cable, grid connection, onshore laboratory facilities, etc.). This is basically a form of capital grant, helping the developers to avoid paying for these items, which can account for over 25% of the costs of a development scheme.
- A report by the Royal Commission on Environmental Pollution (RCEP, 2000) recommended that stronger support be given to wave power, which the Commission considered to have "significant promise".
- A recent public enquiry by the House of Commons Select Committee on Science and Technology concluded:

The enormous potential export market for wave and tidal energy devices easily justifies the public investment now needed to ensure success.

Growth in the wave and tidal energy industry would help to offset unemployment in the declining offshore oil and gas, and shipbuilding, industries. Government investment in wave and tidal energy would thus bring significant economic and social side-effects.